

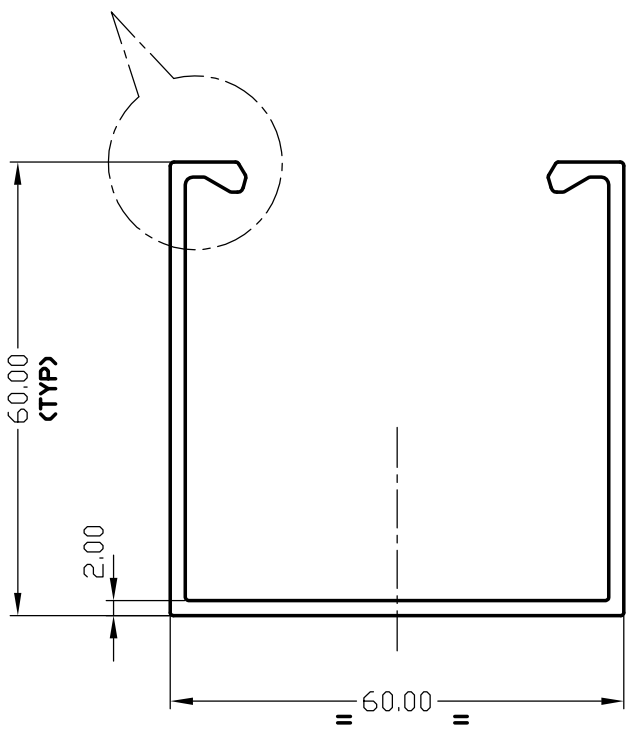

P-2670
S476
9182
28620

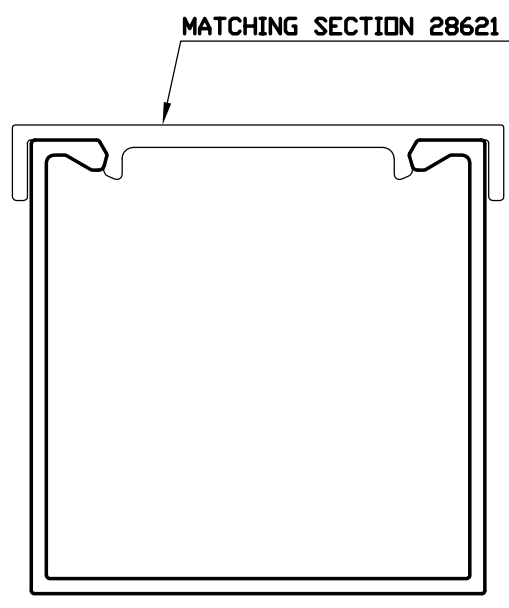
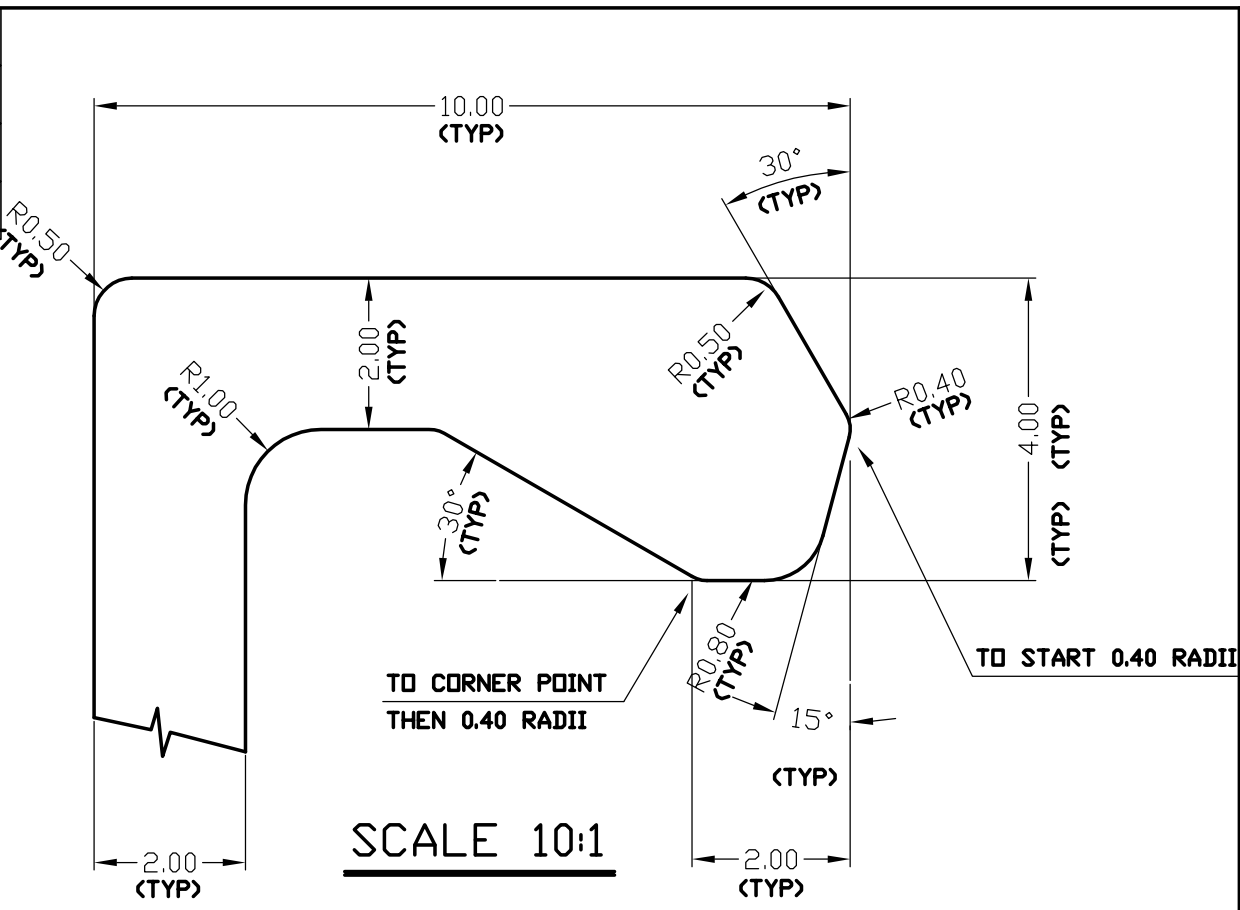

S476

 SYMBOL OF QUALITY AN ISO 9002 COMPANY	JINDAL ALUMINIUM LTD. BANGALORE-560073 (INDIA)	NAME	DATE
		DRAWN	P,KULKARNI 22-2-2000
1. ALL DIMENSIONS ARE IN mm. 2. ROUND OFF ALL SHARP CORNERS WITH 0.40 mm. 3. TOLERANCES WILL BE AS PER IS: 3965-1981 UNLESS OTHERWISE SPECIFIED		CHECKED	
		APPROVED	
		SCALE	1:1
PARTY'S NAME	AVASARALA AUTOMATION LTD., B,LORE.	WEIGHT kg/m	1.070
PARTY'S DRAWING No.	305-08-201-4	SECTION No.	28620
ALLOY & TEMPER	HE9 WP	DRAWING No.	
DESCRIPTION	CABLE DUCT - A	28620	