

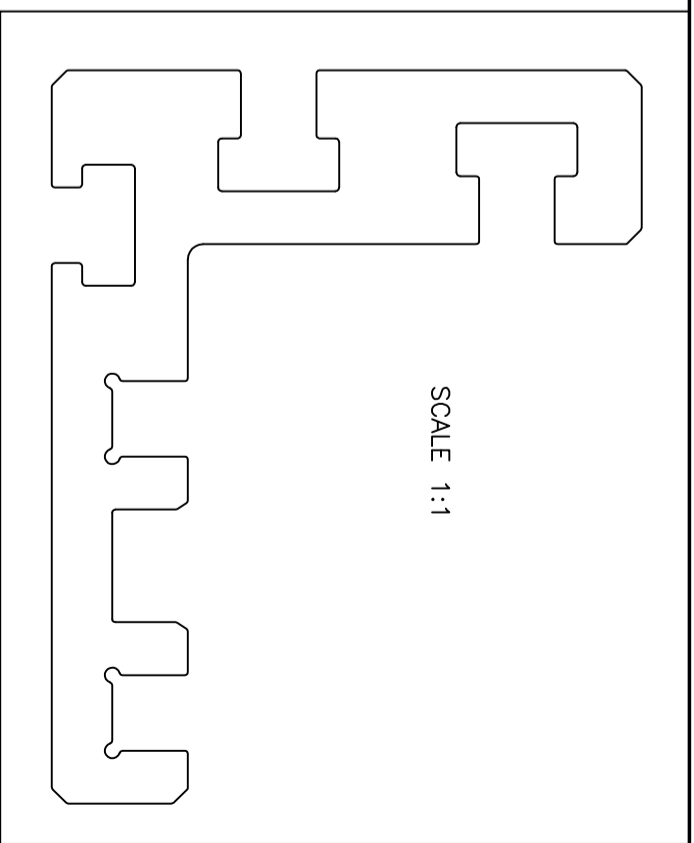

P-7503-1

28631

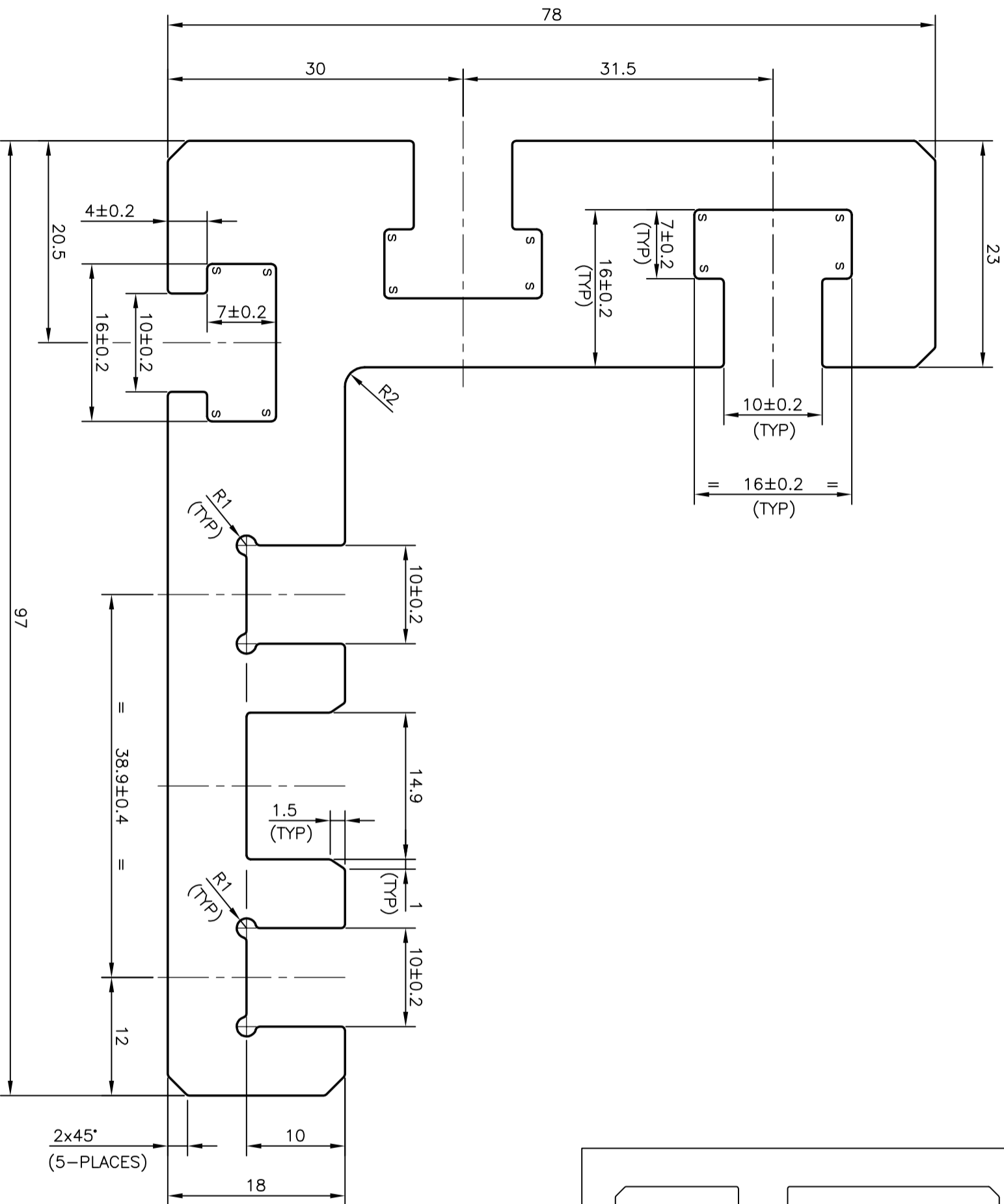

NOTE:-  
1. s = R0.50 mm (8 PLACES)

 SYMBOL OF QUALITY AN ISO 9001 COMPANY		<b>JINDAL ALUMINIUM LTD.</b> BANGALORE-560073 (INDIA)		NAME	DATE
1. ALL DIMENSIONS ARE IN mm. 2. ROUND OFF ALL SHARP CORNERS WITH 0.40 mm. 3. TOLERANCES WILL BE AS PER IS:3965-1981 UNLESS OTHERWISE SPECIFIED		DRAWN	PRASANN. H	19-09-2007	
PARTY'S NAME	KARNATAKA CONVEYORS & SYSTEMS PVT. LTD., HUBLI	CHECKED			
PARTY'S DRAWING No.	K-6285/P-19.05 L	APPROVED			
ALLOY & TEMPER	HE9 WP	SCALE		2:1	
DESCRIPTION	CONVEYOR SECTION	AREA mm <sup>2</sup>		2200.878	
		PERIMETER mm.		527.865	
		WEIGHT kg/m		5.942	
		DRAWING No.		P-7503-1	
		SECTION No.		28631	