

P-7719-1

28648

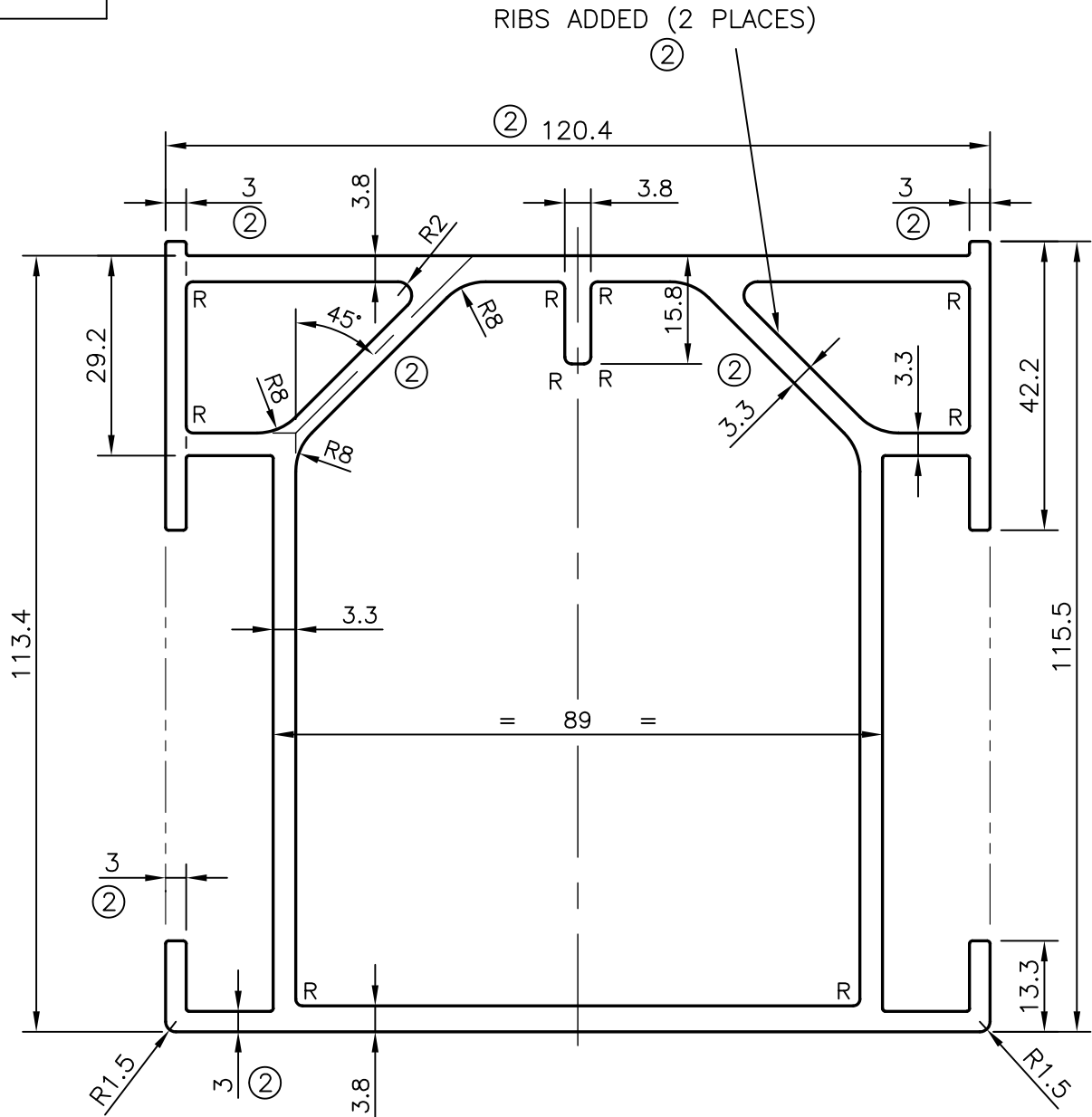

1. R = R1.0 mm (10 PLACES)

ISSUE-2 RIB ADDED (2 PLACES)  
THICKNESS CHANGED 2.8 TO 3mm. (6 PLACES)



SYMBOL OF QUALITY  
AN ISO 9001 COMPANY

**JINDAL ALUMINIUM LTD.**  
BANGALORE-560073 (INDIA)

	NAME	DATE
DRAWN	PARVESH	30-08-2018
CHECKED		
APPROVED	B.NATARAJA	30-08-2018
SCALE		1:1
AREA mm <sup>2</sup>		2094.086
PERIMETER mm.		618.535
WEIGHT kg/m		5.654
DRAWING No.	SECTION No.	
P-7719-1	-	
28648	28648-ISSUE-2	

1. ALL DIMENSIONS ARE IN mm.
2. ROUND OFF ALL SHARP CORNERS WITH 0.40 mm.
3. TOLERANCES WILL BE AS PER IS:6477-1983 UNLESS OTHERWISE SPECIFIED

PARTY'S NAME	GENERAL CATEGORY (OWN USE)
PARTY'S DRAWING No.	AS PER SAMPLE
ALLOY & TEMPER	AS PER REQUIREMENT
DESCRIPTION	CONVEYOR SECTION-P6