

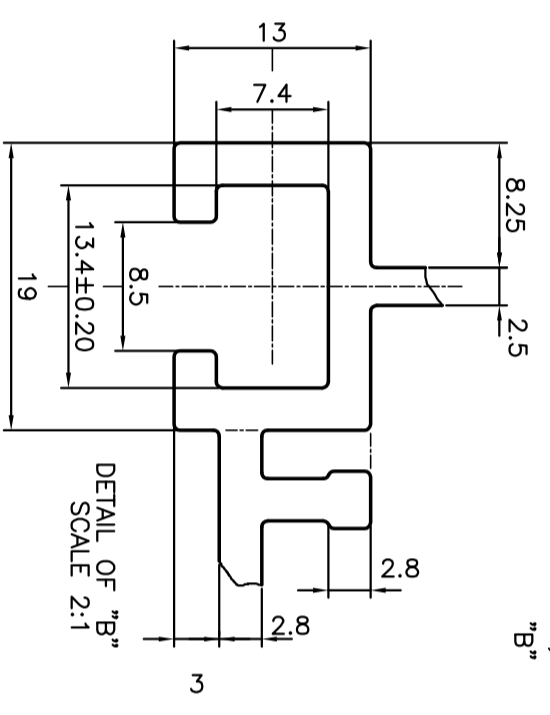

NOTE:-
 1. PROFILE TO BE FREE FROM SCRATCHES, BURRS & DIE LINE
 2. OUT SIDE SURFACE TO BE SMOOTH
 3. TWIST & BEND=1.0mm/M

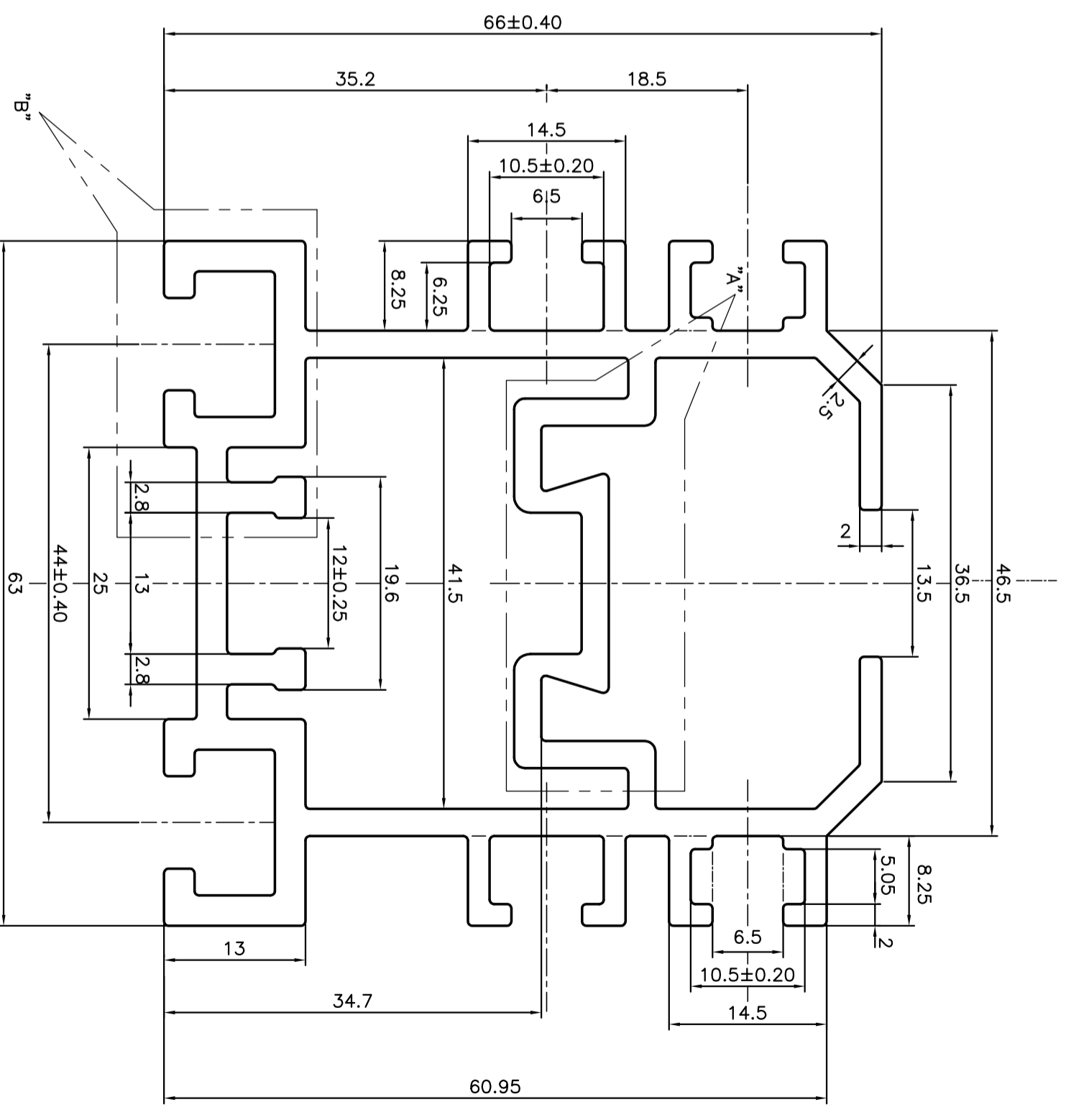
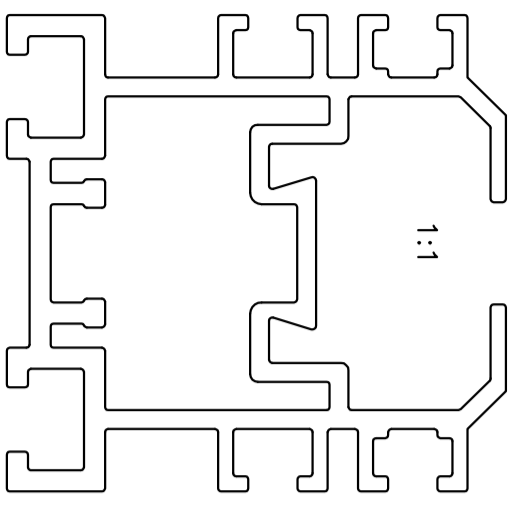

 SYMBOL OF QUALITY AN ISO 9001 COMPANY		JINDAL ALUMINIUM LTD. BANGALORE-560073 (INDIA)		DRAWN	NAME	DATE
				CHECKED	J.P.KAUSHIK	17-06-2011
1. ALL DIMENSIONS ARE IN mm. 2. ROUND OFF ALL SHARP CORNERS WITH 0.40 mm. 3. TOLERANCES WILL BE AS PER IS:6477-1983 UNLESS OTHERWISE SPECIFIED		PARTY'S NAME		AVASARALA TECHNOLOGIES LTD., BANGALORE		
		PARTY'S DRAWING No.		305-00-00546		
ALLOY & TEMPER		HE9 WP				
DESCRIPTION		CONVEYOR SECTION				
SCALE		2:1				
AREA mm ²		1039.07				
PERIMETER mm.		595.578				
WEIGHT kg/m		2.805				
DRAWING No.		SECTION No.				
P-10990-3		-				
X1520		X1520				
28661		28661				