

P-3742

S841

7127

28706

DETAIL "A"
SCALE 5:1

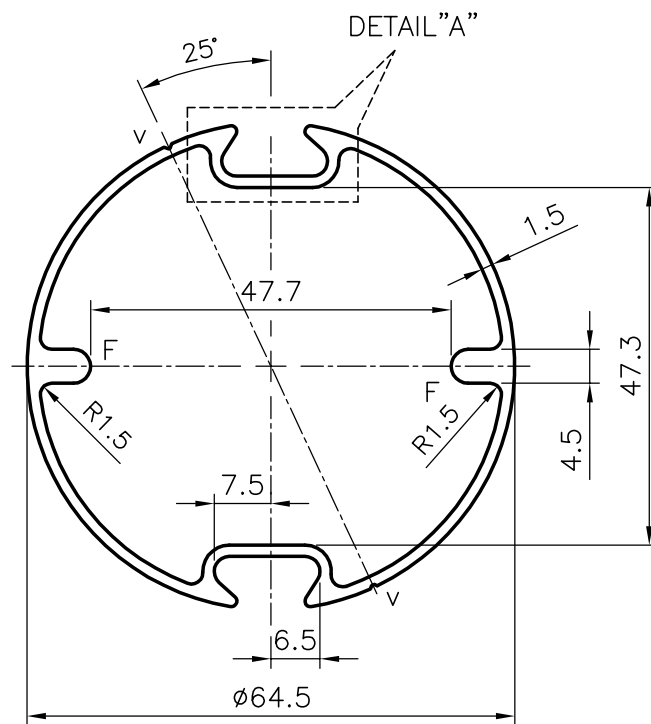
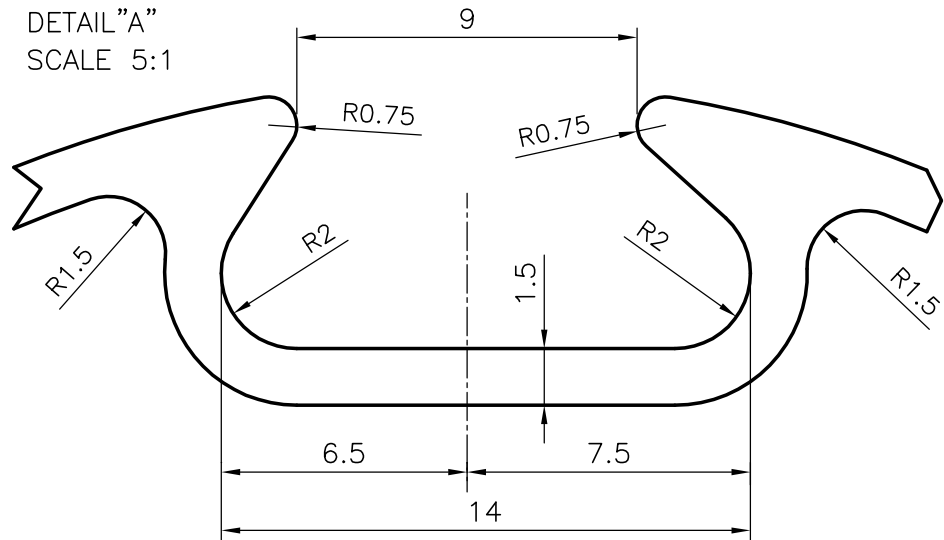

GENERAL WALL THICKNESS = 1.5mm

V = "V" GROOVE 0.5x90° (2 PLACES)



SYMBOL OF QUALITY
AN ISO 9002 COMPANY

JINDAL ALUMINIUM LTD.
BANGALORE-560073 (INDIA)

	NAME	DATE
DRAWN	RAGHAVENDRA	12-01-02
CHECKED		
APPROVED		

1. ALL DIMENSIONS ARE IN mm.
2. ROUND OFF ALL SHARP CORNERS WITH 0.40 mm.
3. TOLERANCES WILL BE AS PER IS 6477-1983 UNLESS OTHERWISE SPECIFIED

SCALE	1:1
AREA mm ²	412.73
PERIMETER	238.59mm
WEIGHT kg/m	1.114
SECTION No.	28706
DRAWING No.	28706

PARTY'S NAME	AMBIENT CONTROLS (P) LTD ., BANGALORE
PARTY'S DRAWING No.	AS PER SAMPLE
ALLOY & TEMPER	HE9 WP
DESCRIPTION	2 1/2" ELECTROSHADE TUBE