

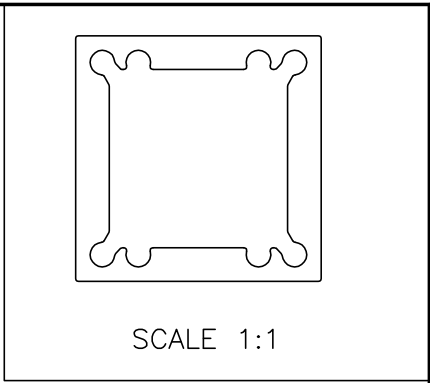

P-2623
S444
8245
28770

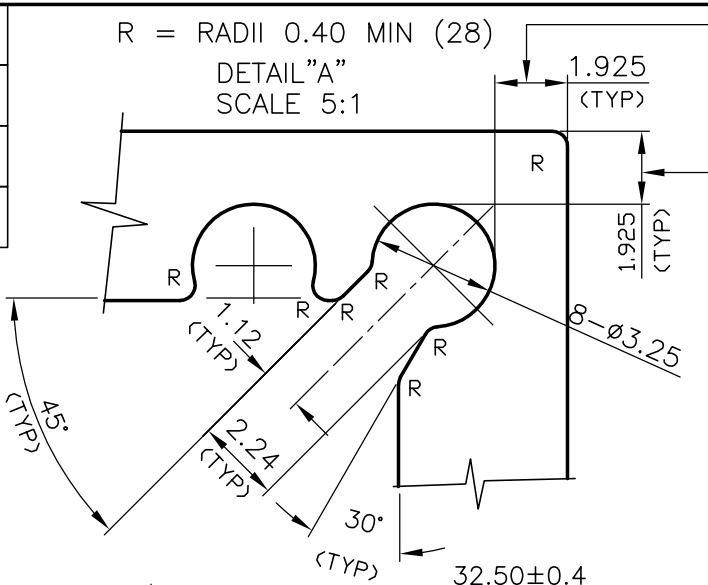

(1.50 MIN THICKNESS AT THIS POINT)

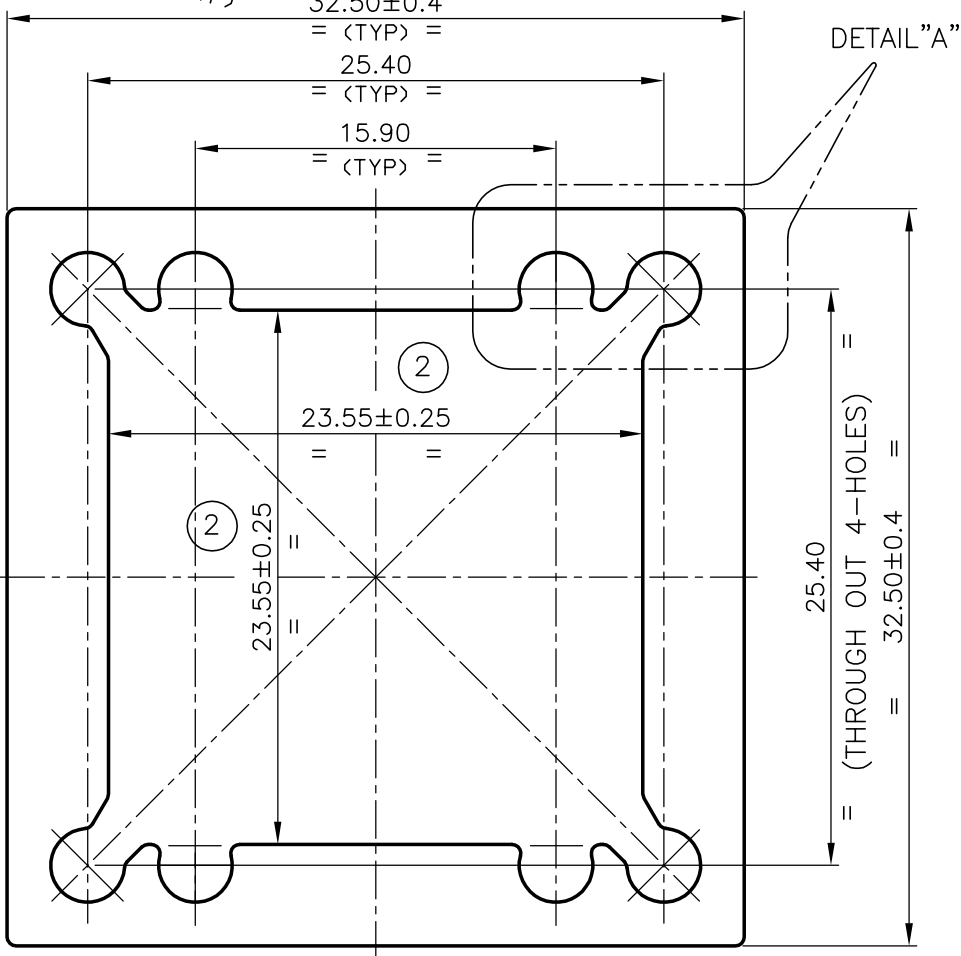

ISSUE-2 DIMENSION CHANGED FROM 23.62 TO 23.55±0.25mm (8245)
ISSUE-2 DIMENSION CHANGED FROM 32.25, 1.8 TO 32.5±0.4, 1.925mm (28770)

 SYMBOL OF QUALITY AN ISO 9002 COMPANY	JINDAL ALUMINIUM LTD. BANGALORE-560073 (INDIA)	DRAWN	NAME	DATE
		CHECKED	MALINGAPPA	05-02-2005
1. ALL DIMENSIONS ARE IN mm. 2. ROUND OFF ALL SHARP CORNERS WITH 0.40 mm. 3. TOLERANCES WILL BE AS PER IS:6477-1983 UNLESS OTHERWISE SPECIFIED		APPROVED		
		SCALE		3:1
PARTY'S NAME		AREA	mm ²	435.511
		PERIMETER	mm.	129.31
PARTY'S DRAWING No.		WEIGHT	kg/m	1.176
		DRAWING No.	SECTION No.	
ALLOY & TEMPER		P-2623	-	
		S444	S444	
DESCRIPTION		8245	8245-ISSUE-2	
		28770	28770-ISSUE-2	