

P-5182-1

28800

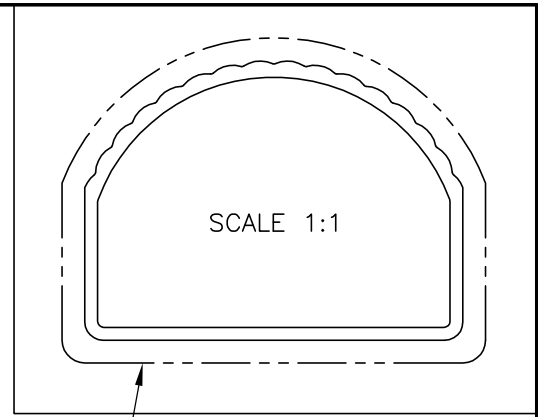

EXPOSED SURFACE BETTER FINISH REQUIRED

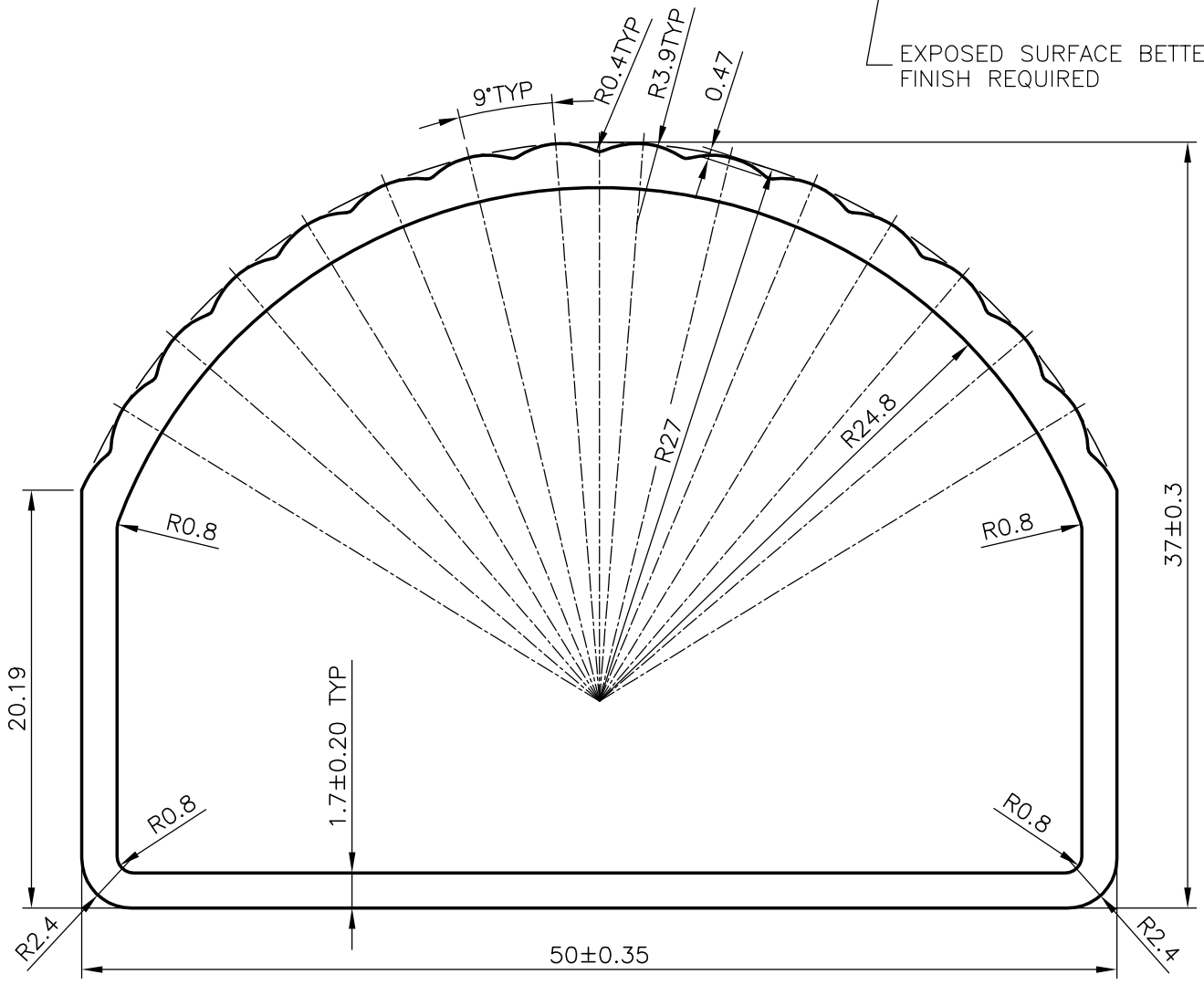

SYMBOL OF QUALITY
AN ISO 9001 COMPANY

JINDAL ALUMINIUM LTD.
BANGALORE-560073 (INDIA)

	NAME	DATE
DRAWN	RAGHAVENDRA	17-12-2004
CHECKED		
APPROVED		

1. ALL DIMENSIONS ARE IN mm.
2. ROUND OFF ALL SHARP CORNERS WITH 0.40 mm.
3. TOLERANCES WILL BE AS PER DIN-17615 PART-3 UNLESS OTHERWISE SPECIFIED

SCALE	3:1
AREA mm ²	269.102
PERIMETER mm.	153.941
WEIGHT kg/m	0.727

PARTY'S NAME	MAYFAIR IMPORTS, AUSTRALIA
PARTY'S DRAWING No.	AS PER SKETCH
ALLOY & TEMPER	6063 T6
DESCRIPTION	MISC. TUBE

DRAWING No.	SECTION No.
P-5182-1	-
28800	28800