

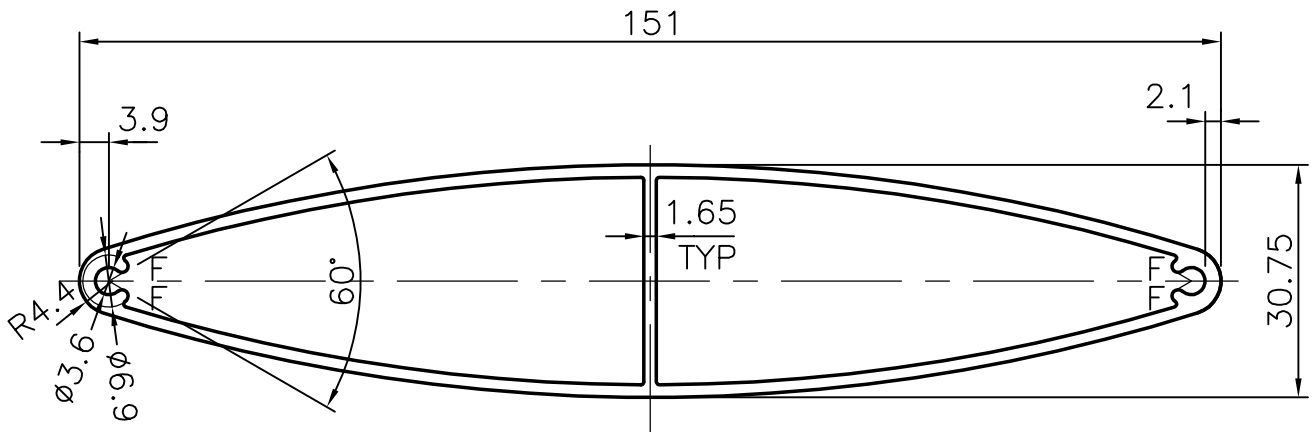

P-5418-1

28803



F = FULL RADIUS (4 PLACES)

GENERAL WALL THICKNESS = 1.65mm

 SYMBOL OF QUALITY AN ISO 9001 COMPANY	JINDAL ALUMINIUM LTD. BANGALORE-560073 (INDIA)	NAME	DATE
		DRAWN	MALINGAPPA 15.04.2005
1. ALL DIMENSIONS ARE IN mm. 2. ROUND OFF ALL SHARP CORNERS WITH 0.40 mm. 3. TOLERANCES WILL BE AS PER IS: 6477-1983 UNLESS OTHERWISE SPECIFIED		CHECKED	
		APPROVED	
PARTY'S NAME GENERAL CATEGORY, MUMBAI MARKET		SCALE	1:1
		AREA mm ²	582.521
PARTY'S DRAWING No. AS PER SAMPLE		PERIMETER mm.	316.542
		WEIGHT kg/m	1.573
ALLOY & TEMPER HE9 WP		DRAWING No.	SECTION No.
		P-5418-1	
DESCRIPTION MISCELLANEOUS HOLLOW		28803	28803