

P-5800

28807

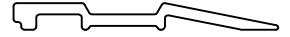

1:1

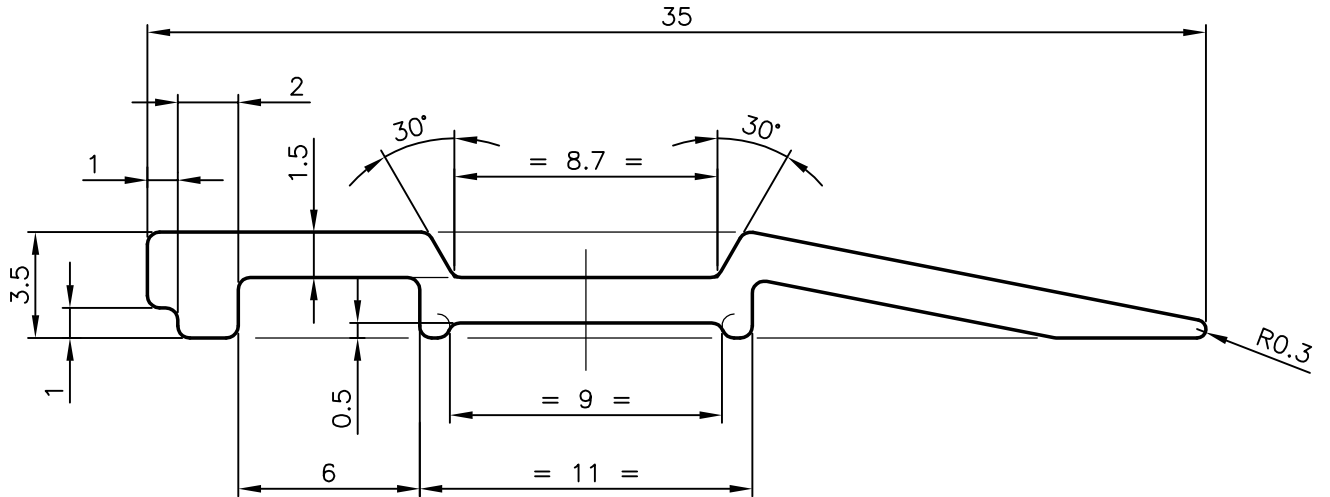

REQUIRED LENGTH = 163 mm



SYMBOL OF QUALITY
AN ISO 9001 COMPANY

JINDAL ALUMINIUM LTD.
BANGALORE-560073 (INDIA)

	NAME	DATE
DRAWN	MALINGAPPA	09-08-2005
CHECKED		
APPROVED		

1. ALL DIMENSIONS ARE IN mm.
2. ROUND OFF ALL SHARP CORNERS WITH 0.40 mm.
3. TOLERANCES WILL BE AS PER IS:3965-1981 UNLESS OTHERWISE SPECIFIED

SCALE	4:1
AREA mm ²	58.518
PERIMETER mm.	80.445
WEIGHT kg/m	0.158

PARTY'S NAME	OWN USE
PARTY'S DRAWING No.	AS PER SAMPLE
ALLOY & TEMPER	HE9 WP
DESCRIPTION	SMALL SCALE- GIFT SECTION

DRAWING No.	SECTION No.
P-5800	-
28807	28807