

P-5704

28810

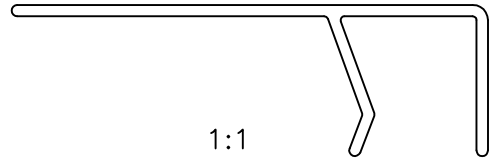

1:1

F = FULL RADIUS (3 PLACES)  
 GENERAL WALL THICKNESS = 1.5 mm  
 UNSPECIFIED TOLERANCES:- ± 0.20

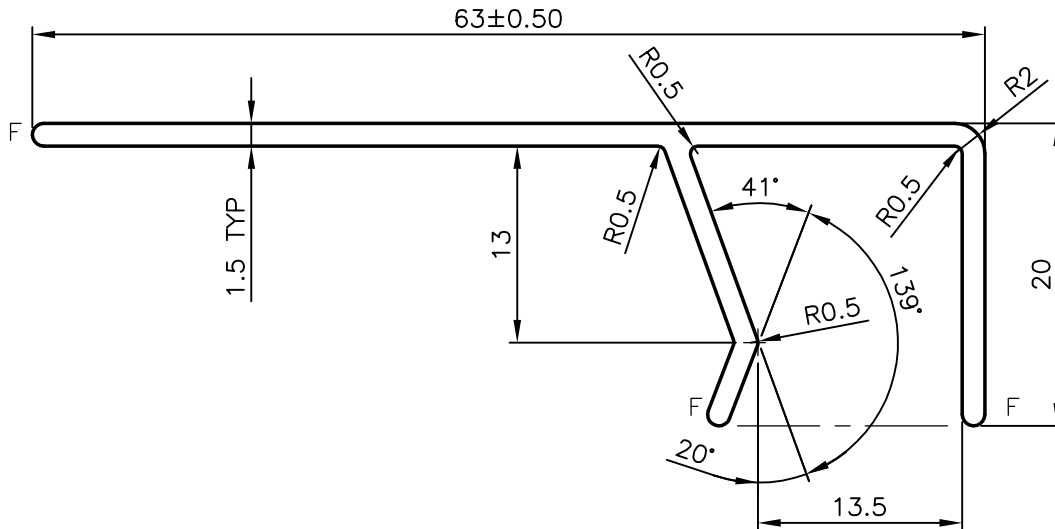

SYMBOL OF QUALITY  
 AN ISO 9001 COMPANY

**JINDAL ALUMINIUM LTD.**  
 BANGALORE-560073 (INDIA)

	NAME	DATE
DRAWN	MALINGAPPA	20-07-2005
CHECKED		
APPROVED		

1. ALL DIMENSIONS ARE IN mm.
2. ROUND OFF ALL SHARP CORNERS WITH 0.40 mm.
3. TOLERANCES WILL BE AS PER BS:1474-1987 UNLESS OTHERWISE SPECIFIED

SCALE	2:1
AREA mm <sup>2</sup>	150.367
PERIMETER mm.	201.657
WEIGHT kg/m	0.406

PARTY'S NAME	MEDIA PROJECT, U.K.	DRAWING No.	P-5704	SECTION No.	-
PARTY'S DRAWING No.	AS PER DRAWING - 6942		28810		28810
ALLOY & TEMPER	6063 T6				
DESCRIPTION	MISCELLANEOUS SECTION				