

P-5864

28812

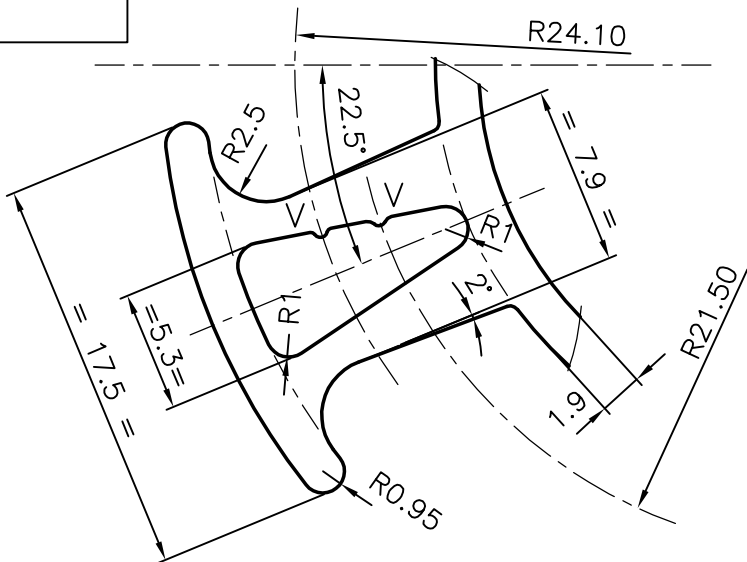

DETAIL-A
SCALE:3:1

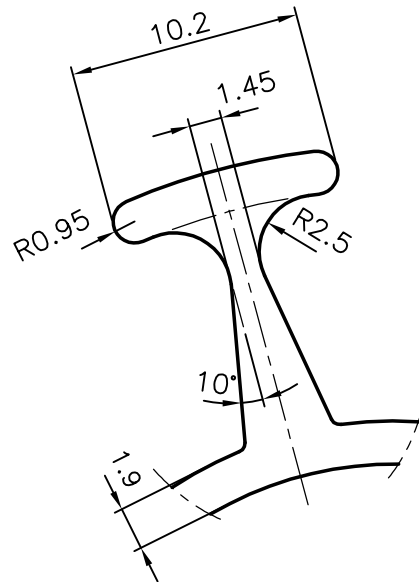

DETAIL-B
SCALE:3:1

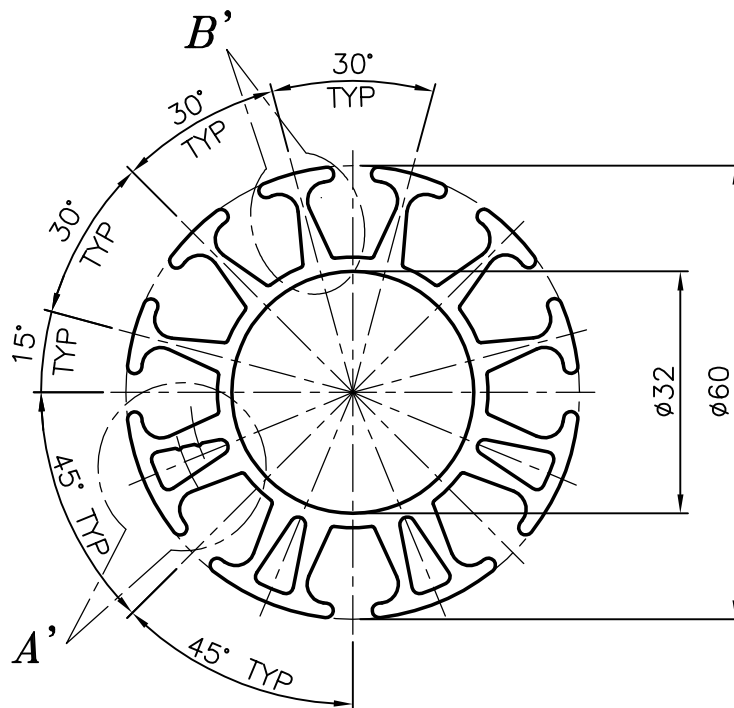

GENERAL WALL THICKNESS = 1.9 mm
 $V = 0.3 \times 90^\circ \times R0.3$ (2 PLACES)



SYMBOL OF QUALITY
 AN ISO 9001 COMPANY

JINDAL ALUMINIUM LTD.
 BANGALORE-560073 (INDIA)

	NAME	DATE
DRAWN	MALINGAPPA	12-09-2005
CHECKED		
APPROVED		

1. ALL DIMENSIONS ARE IN mm.
2. ROUND OFF ALL SHARP CORNERS WITH 0.40 mm.
3. TOLERANCES WILL BE AS PER IS:6477-1983 UNLESS OTHERWISE SPECIFIED

SCALE	1:1
AREA mm ²	814.284
PERIMETER mm.	477.719
WEIGHT kg/m	2.199

PARTY'S NAME	OWN USE
PARTY'S DRAWING No.	AS PER SAMPLE
ALLOY & TEMPER	HE9 WP
DESCRIPTION	GIFT SECTION

DRAWING No.	SECTION No.
P-5864	-
28812	28812