

P-6254

28814

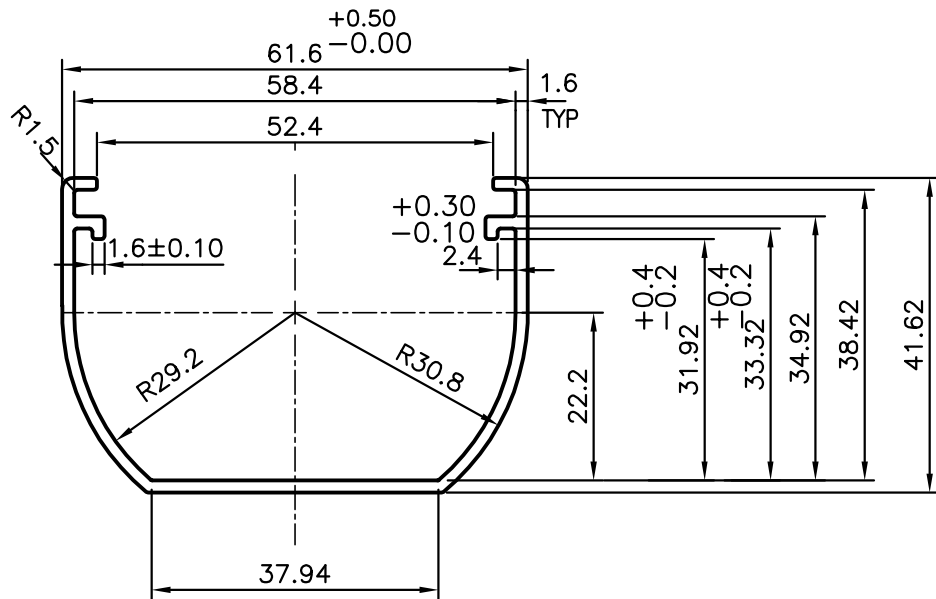
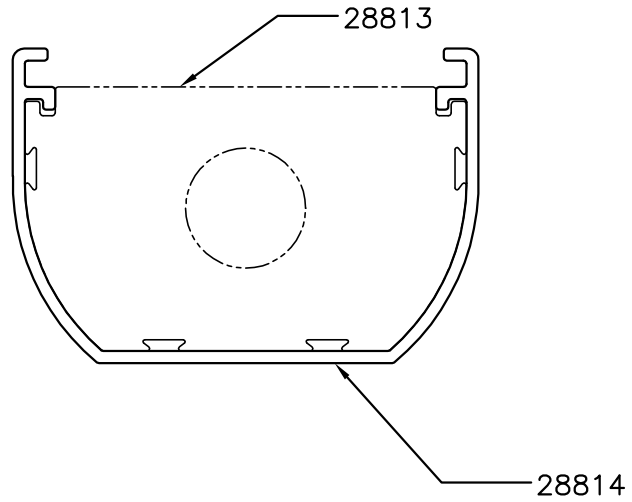

GENERAL WALL THICKNESS 1.60 (TYP)

SECTION MATCHING WITH 28813



SYMBOL OF QUALITY  
AN ISO 9002 COMPANY

**JINDAL ALUMINIUM LTD.**  
BANGALORE-560073 (INDIA)

	NAME	DATE
DRAWN	J.P.KAUSHIK	16-03-2006
CHECKED		
APPROVED		
SCALE		1:1
AREA mm <sup>2</sup>		228.366
PERIMETER mm.		285.562
WEIGHT kg/m		0.617
DRAWING No.	SECTION No.	
P-6254	-	
28814	28814	

1. ALL DIMENSIONS ARE IN mm.
2. ROUND OFF ALL SHARP CORNERS WITH 0.40 mm.
3. TOLERANCES WILL BE AS PER COMMERCIAL UNLESS OTHERWISE SPECIFIED

PARTY'S NAME	PROSOURCE SOLUTIONS INC., CANADA
PARTY'S DRAWING No.	TG-10-EXT
ALLOY & TEMPER	6063 T5
DESCRIPTION	MISC. SECTION