

P-6430-1
S1760
28851

F = FULL RADIUS (3 PLACES)
A = R0.5 (9 PLACES)
B = R1.0 (3 PLACES)

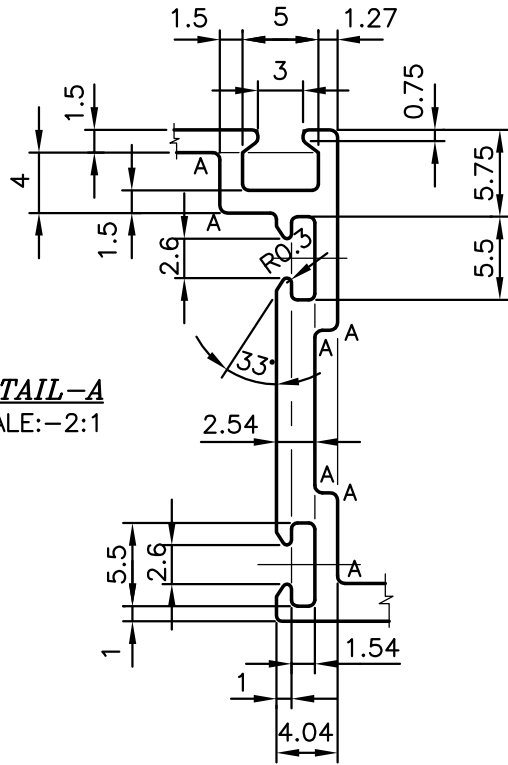

DETAIL-A
SCALE:-2:1

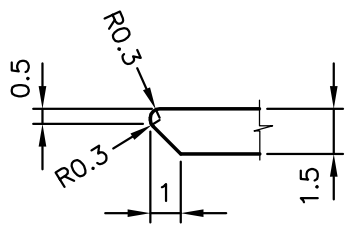

DETAIL-C
SCALE:-4:1

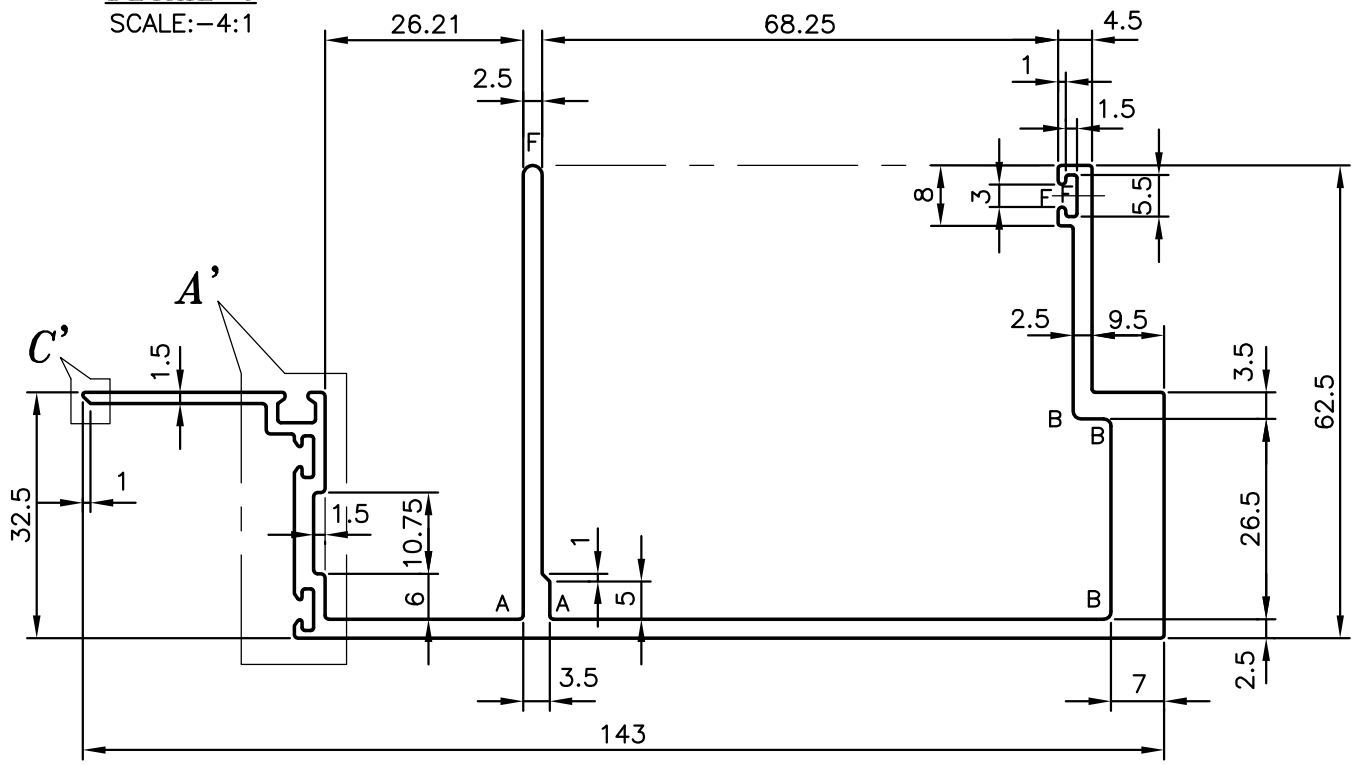

JINDAL ALUMINIUM LTD.
BANGALORE-560073 (INDIA)

	NAME	DATE
DRAWN	MALINGAPPA	01-06-2006
CHECKED		
APPROVED		
SCALE		1:1
AREA mm ²		870.586
PERIMETER mm.		637.595
WEIGHT kg/m		2.351
DRAWING No.	SECTION No.	
P-6430-1	-	
S1760	S1760	
28851	28851	

1. ALL DIMENSIONS ARE IN mm.
2. ROUND OFF ALL SHARP CORNERS WITH 0.40 mm.
3. TOLERANCES WILL BE AS PER IS:3965-1981 UNLESS OTHERWISE SPECIFIED

PARTY'S NAME	GWS FABRICATORS PVT,LTD., MUMBAI
PARTY'S DRAWING No.	GWS-UTM-115
ALLOY & TEMPER	6063 T6
DESCRIPTION	MALE MULLION SECTION