

P-6433-1

S1763

28854

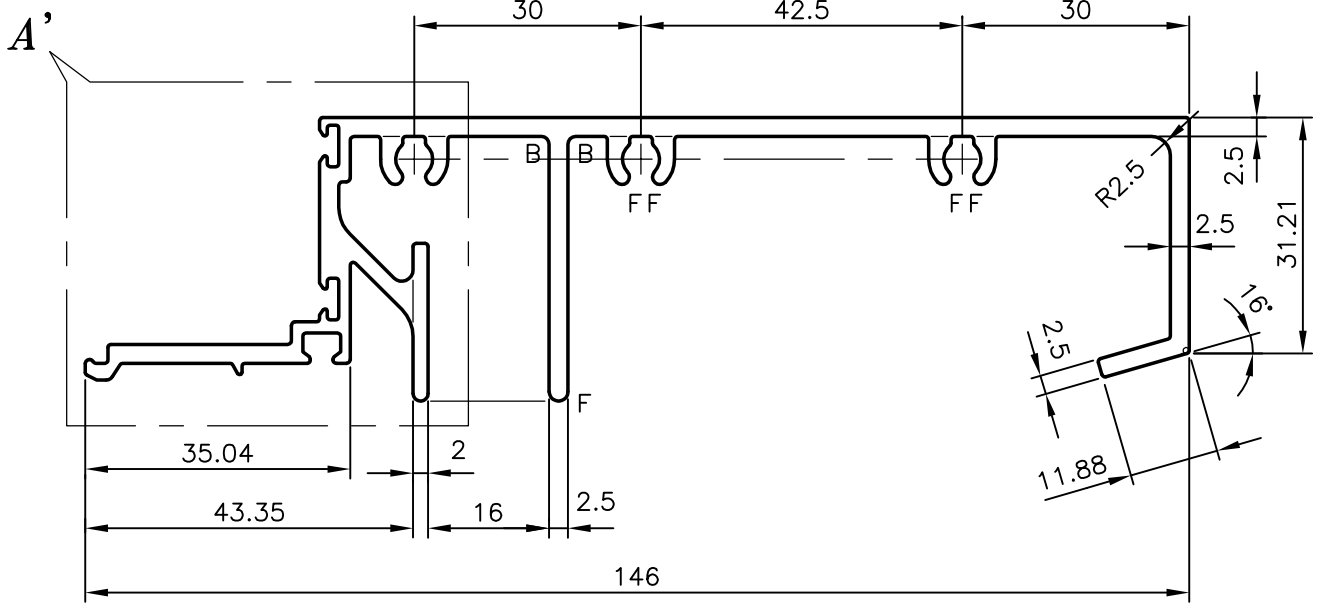
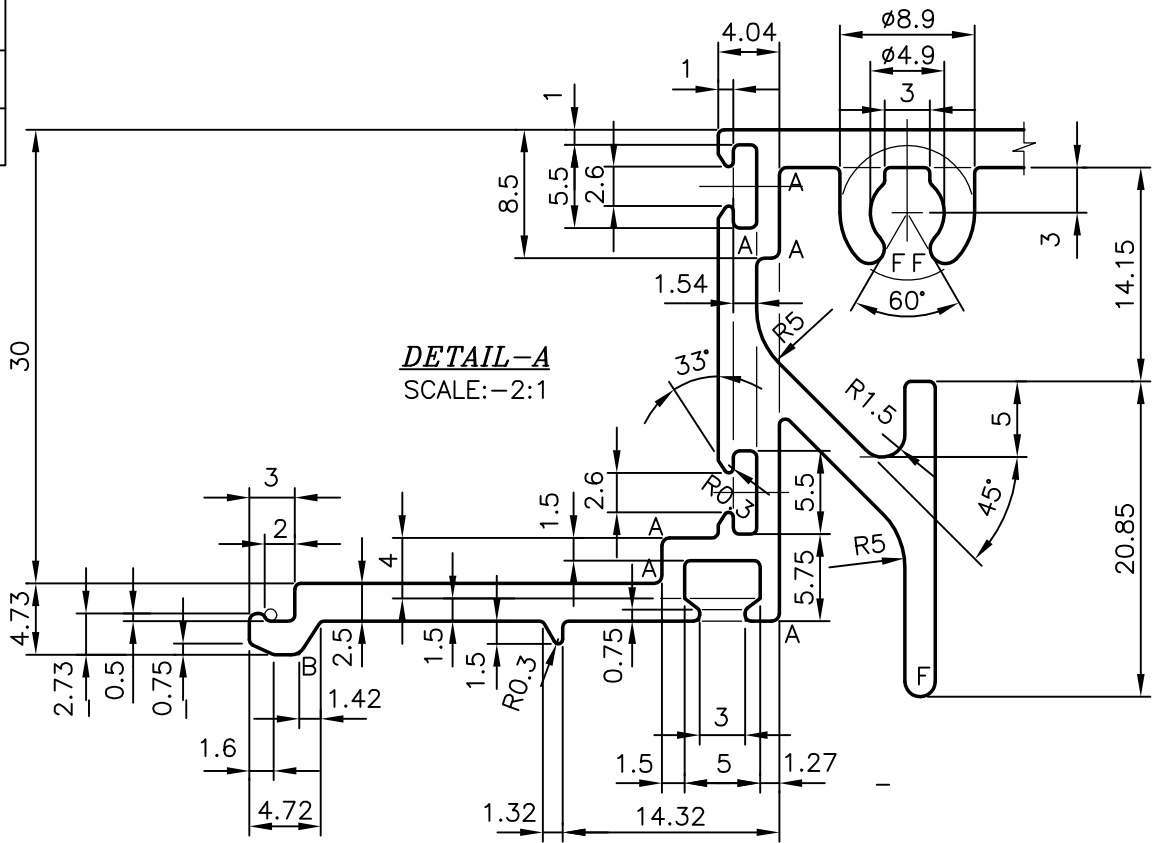

F = FULL RADIUS (8 PLACES)
 A = R0.5 (6 PLACES)
 B = R1.0 (3 PLACES)



SYMBOL OF QUALITY
 AN ISO 9001 COMPANY

JINDAL ALUMINIUM LTD.
 BANGALORE-560073 (INDIA)

	NAME	DATE
DRAWN	MALINGAPPA	03-06-2006
CHECKED		
APPROVED		

- ALL DIMENSIONS ARE IN mm.
- ROUND OFF ALL SHARP CORNERS WITH 0.40 mm.
- TOLERANCES WILL BE AS PER IS:3965-1981 UNLESS OTHERWISE SPECIFIED

SCALE	1:1
AREA mm ²	792.593
PERIMETER mm.	658.906
WEIGHT kg/m	2.140

PARTY'S NAME	GWS FABRICATORS PVT,LTD., MUMBAI
PARTY'S DRAWING No.	GWS-UTF-115
ALLOY & TEMPER	6063 T6
DESCRIPTION	SILL SECTION

DRAWING No.	SECTION No.
P-6433-1	-
S1763	S1763
28854	28854