

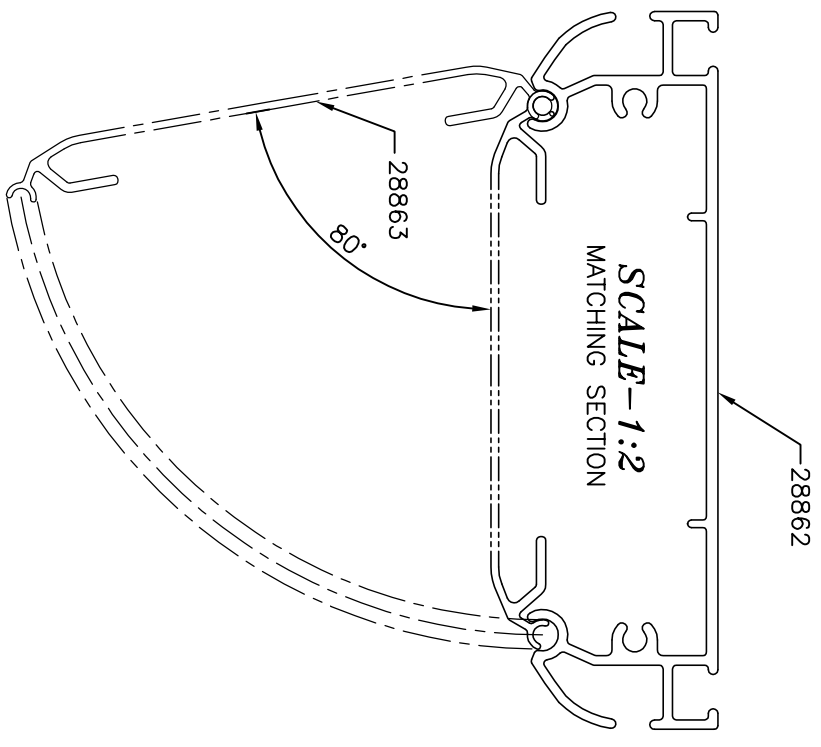

P-4840-3
S1225
28862

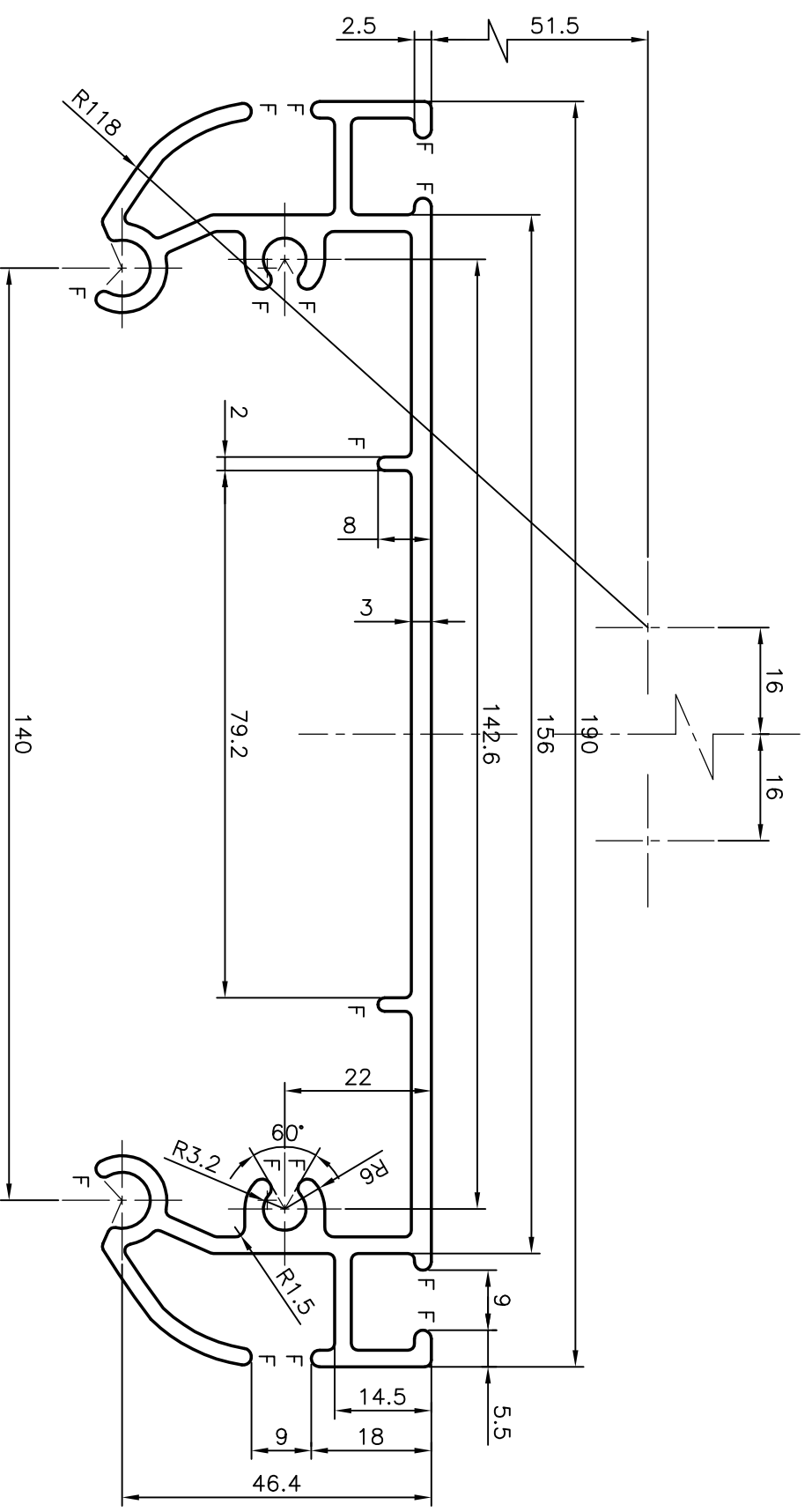
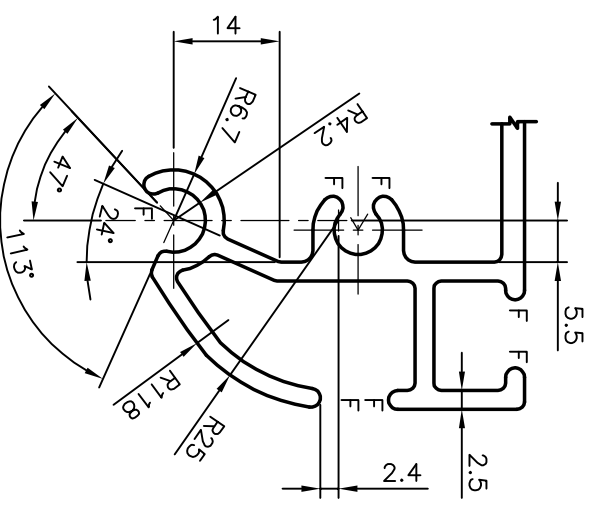

GENERAL WALL THICKNESS = 2.5 mm
F = FULL RADIUS
UNSPECIFIED CORNER RADIOS = 1R

 SYMBOL OF QUALITY AN ISO 9001 COMPANY	JINDAL ALUMINIUM LTD. BANGALORE-560073 (INDIA)		DRAWN	NAME	DATE
	1. ALL DIMENSIONS ARE IN mm. 2. ROUND OFF ALL SHARP CORNERS WITH 0.40 mm. 3. TOLERANCES WILL BE AS PER IS: 3965-1981 UNLESS OTHERWISE SPECIFIED		CHECKED	MALINGAPPA	24.05.2004
PARTY'S NAME	METALBEDS INDIA PVT. LTD., MAHARASHTRA	APPROVED			
PARTY'S DRAWING No.	AS PER DRAWING	SCALE			1:1
ALLOY & TEMPER	HE9 WP	AREA mm ²			1248.28
DESCRIPTION	MISCELLANEOUS SECTION	PERIMETER mm.			882.22
		WEIGHT kg/m			3.370
		DRAWING No.		SECTION No.	
		P-4840-3		-	
		S1225		S1225	
		28862		28862	