

P-4841-3

S1226

28863

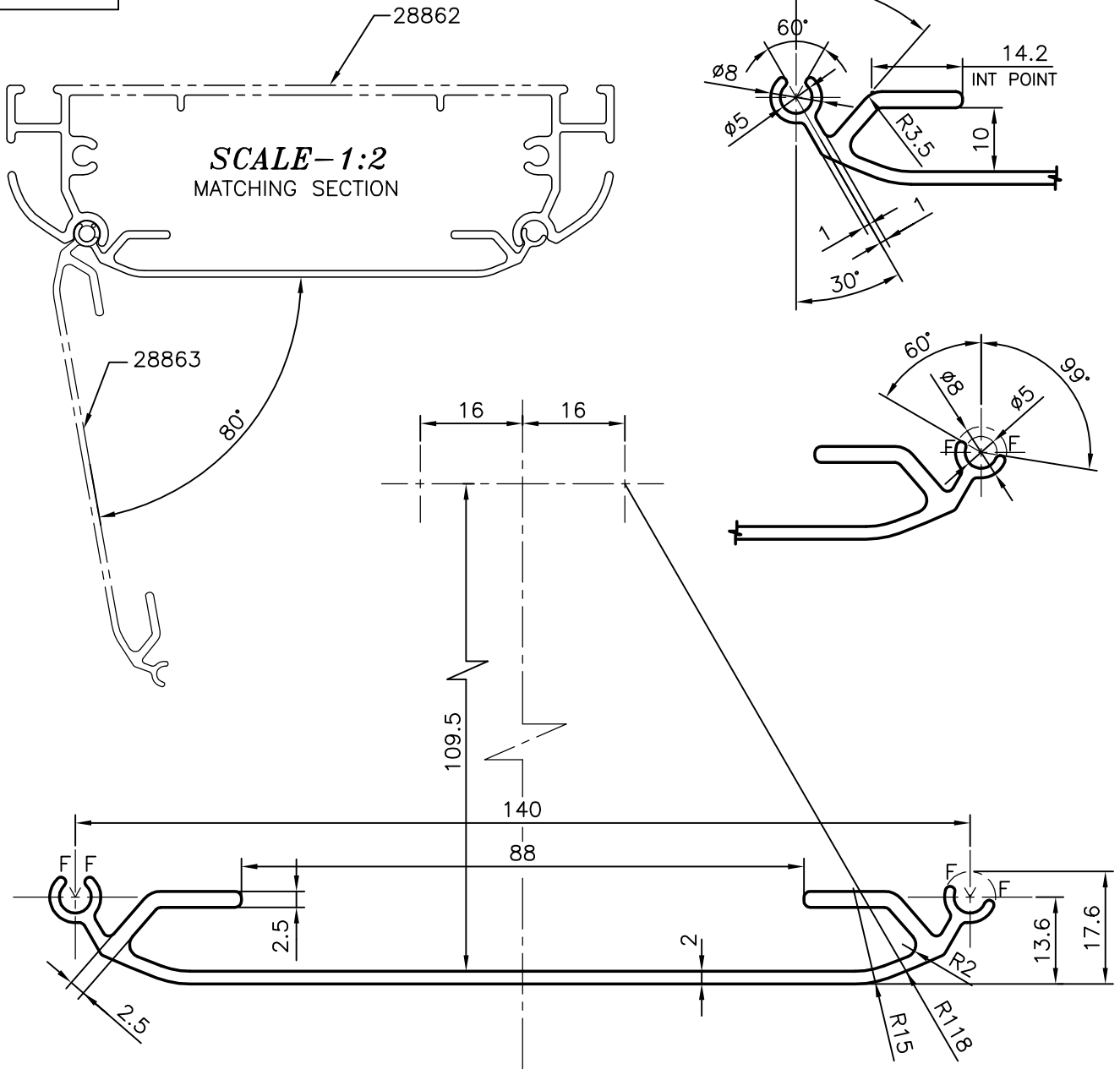

F = FULL RADIUS
 UNSPECIFIED CORNER RADIOS = 1R



SYMBOL OF QUALITY
 AN ISO 9001 COMPANY

JINDAL ALUMINIUM LTD.
 BANGALORE-560073 (INDIA)

	NAME	DATE
DRAWN	MALINGAPPA	24.05.2004
CHECKED		
APPROVED		
SCALE		1:1
AREA mm ²		447.74
PERIMETER mm.		426.95
WEIGHT kg/m		1.209
DRAWING No.	SECTION No.	
P-4841-3	-	
S1226	S1226	
28863	28863	

- ALL DIMENSIONS ARE IN mm.
- ROUND OFF ALL SHARP CORNERS WITH 0.40 mm.
- TOLERANCES WILL BE AS PER IS: 3965-1981 UNLESS OTHERWISE SPECIFIED

PARTY'S NAME	METALBEDS INDIA PVT. LTD., MAHARASHTRA
PARTY'S DRAWING No.	AS PER DRAWING
ALLOY & TEMPER	HE9 WP
DESCRIPTION	MISCELLANEOUS SECTION