

P-6708

28878



UNSPECIFIED WALL THICKNESS = 2.16mm

R = 3.3 RADIUS (2 PLACES)

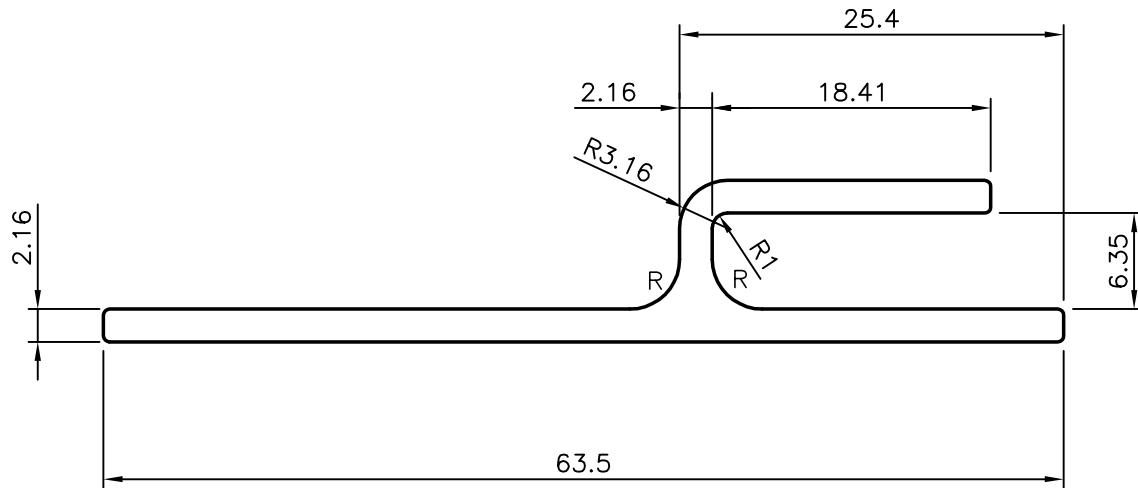

 SYMBOL OF QUALITY AN ISO 9001 COMPANY	JINDAL ALUMINIUM LTD. BANGALORE-560073 (INDIA)	NAME		DATE
		DRAWN	J.P.KAUSHIK	28-09-2006
1. ALL DIMENSIONS ARE IN mm. 2. ROUND OFF ALL SHARP CORNERS WITH 0.40 mm. 3. TOLERANCES WILL BE AS PER BS:1474-1987 UNLESS OTHERWISE SPECIFIED		CHECKED		
		APPROVED		
PARTY'S NAME PROSOURCE SOLUTIONS INC., CANADA		SCALE		2:1
		AREA mm ²		197.653
PARTY'S DRAWING No. DJ-30		PERIMETER mm.		179.452
		WEIGHT kg/m		0.534
ALLOY & TEMPER 6060 T5		DRAWING No.		SECTION No.
		P-6708		-
DESCRIPTION MISC. SECTION		28878		28878