

P-6703

28880

MATCHING SECTION  
SCALE 2:1

28880

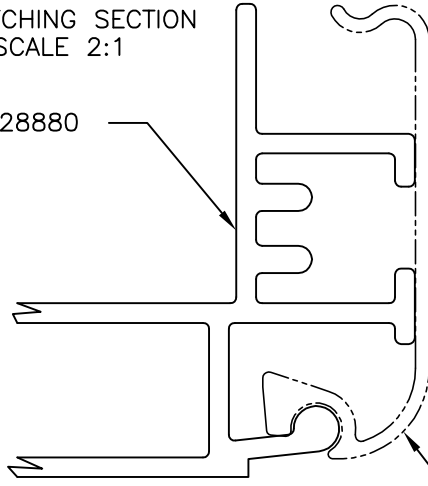

28881

SCALE 1:1

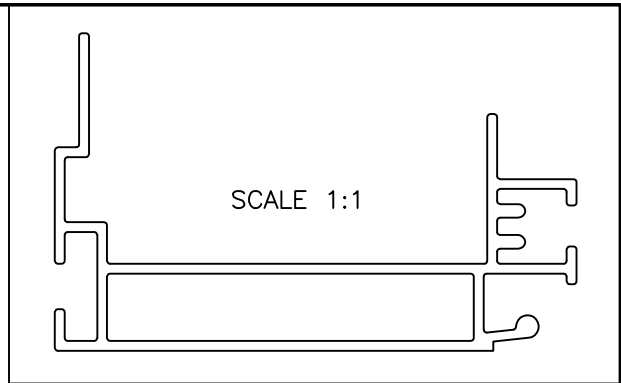

GENERAL WALL THICKNESS = 1.30mm

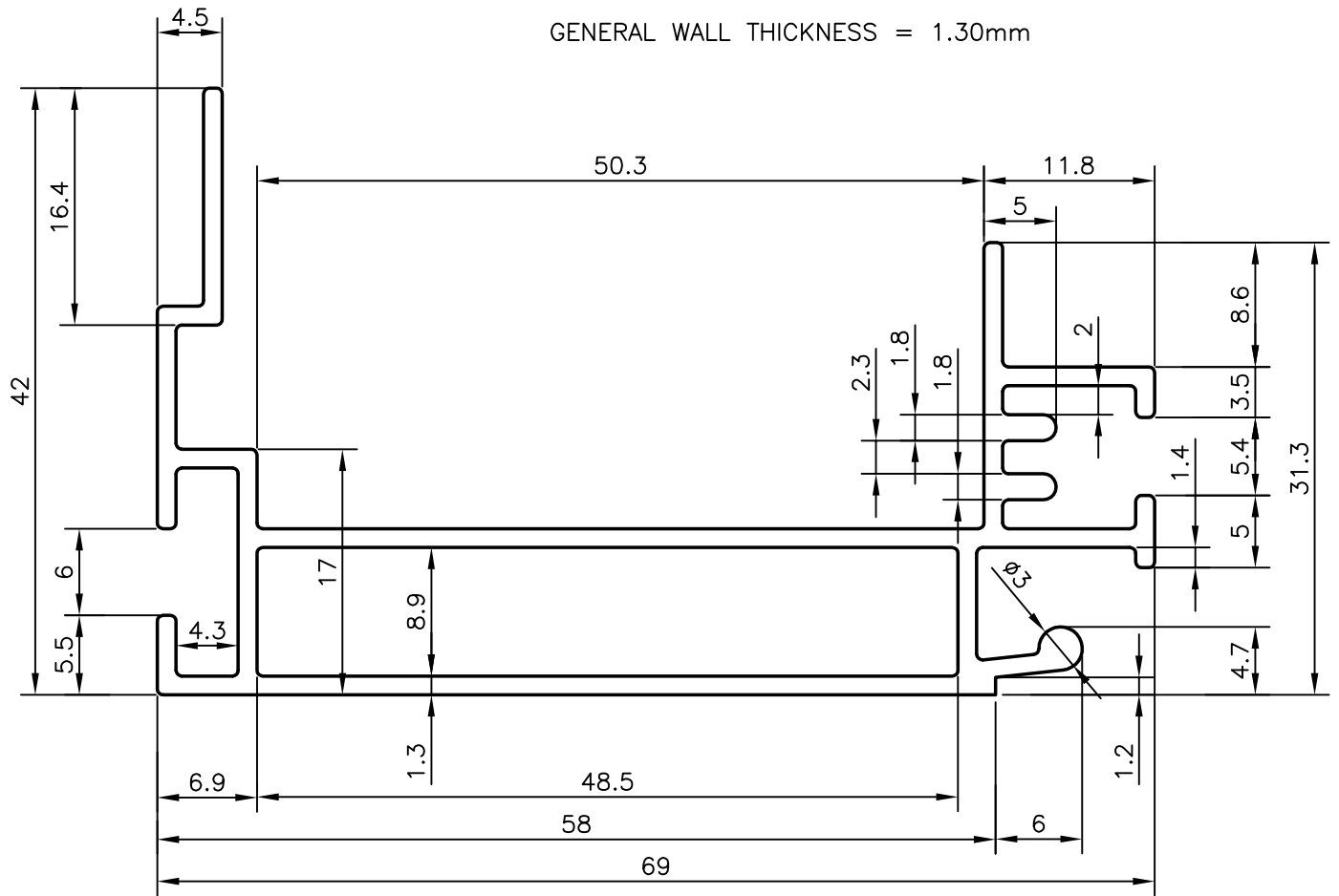

SYMBOL OF QUALITY  
AN ISO 9001 COMPANY

**JINDAL ALUMINIUM LTD.**  
BANGALORE-560073 (INDIA)

|          | NAME        | DATE       |
|----------|-------------|------------|
| DRAWN    | RAGHAVENDRA | 28-09-2006 |
| CHECKED  |             |            |
| APPROVED |             |            |

1. ALL DIMENSIONS ARE IN mm.
2. ROUND OFF ALL SHARP CORNERS WITH 0.40 mm.
3. TOLERANCES WILL BE AS PER IS:6477-1983 UNLESS OTHERWISE SPECIFIED

|                      |         |
|----------------------|---------|
| SCALE                | 2:1     |
| AREA mm <sup>2</sup> | 315.986 |
| PERIMETER mm.        | 351.427 |
| WEIGHT kg/m          | 0.853   |

|                     |                                 |             |        |             |       |
|---------------------|---------------------------------|-------------|--------|-------------|-------|
| PARTY'S NAME        | GENERAL CATEGORY, MUMBAI MARKET | DRAWING No. | P-6703 | SECTION No. | -     |
| PARTY'S DRAWING No. | AS PER SAMPLE                   |             | 28880  |             | 28880 |
| ALLOY & TEMPER      | HE9 WP                          |             |        |             |       |
| DESCRIPTION         | MISC. SECTION                   |             |        |             |       |