

P-6704

28881

MATCHING SECTION
SCALE 2:1

28880

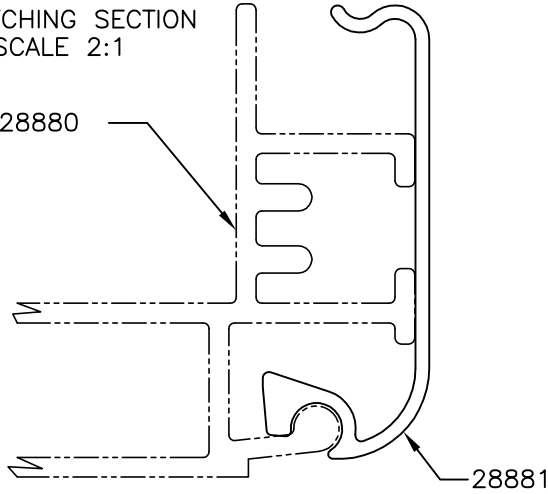

SCALE 1:1

GENERAL WALL THICKNESS = 0.90mm

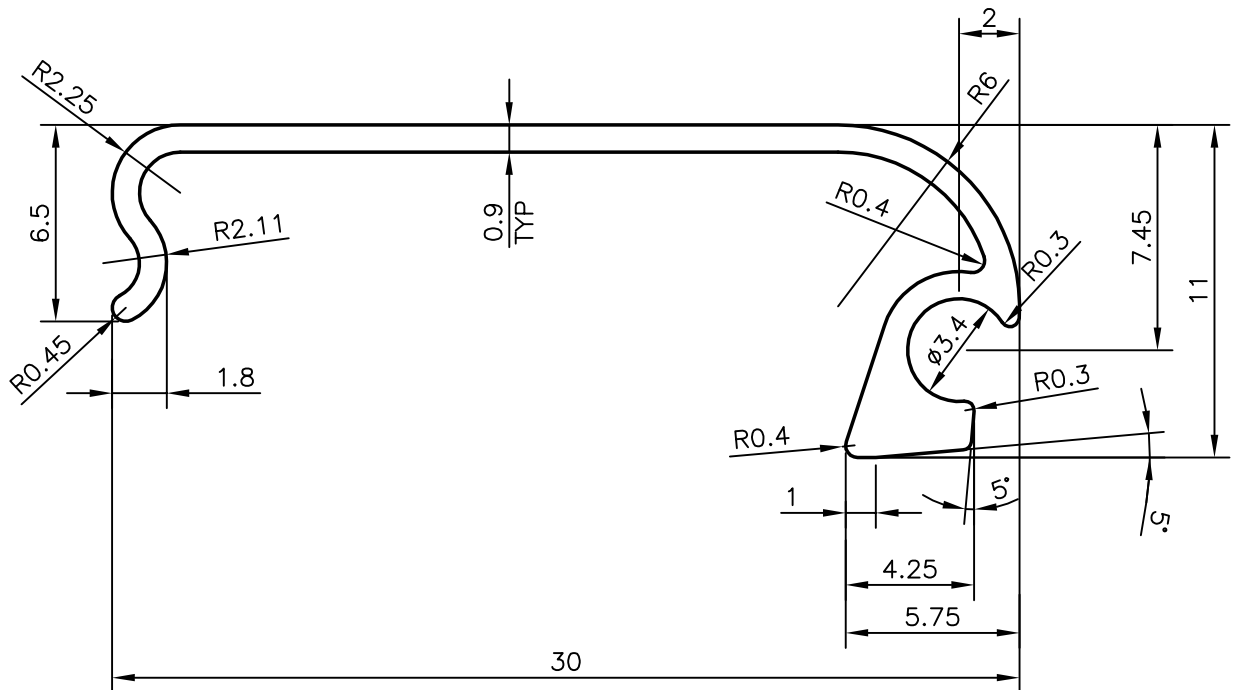

SYMBOL OF QUALITY
AN ISO 9001 COMPANY

JINDAL ALUMINIUM LTD.
BANGALORE-560073 (INDIA)

	NAME	DATE
DRAWN	RAGHAVENDRA	28-09-2006
CHECKED		
APPROVED		

1. ALL DIMENSIONS ARE IN mm.
2. ROUND OFF ALL SHARP CORNERS WITH 0.40 mm.
3. TOLERANCES WILL BE AS PER IS:3965-1981 UNLESS OTHERWISE SPECIFIED

SCALE	4:1
AREA mm ²	48.681
PERIMETER mm.	98.154
WEIGHT kg/m	0.131

PARTY'S NAME GENERAL CATEGORY, MUMBAI MARKET

PARTY'S DRAWING No. AS PER SAMPLE

ALLOY & TEMPER HE9 WP

DESCRIPTION MISC. SECTION

DRAWING No.	SECTION No.
P-6704	-
28881	28881