

P-5862
S1590
28884

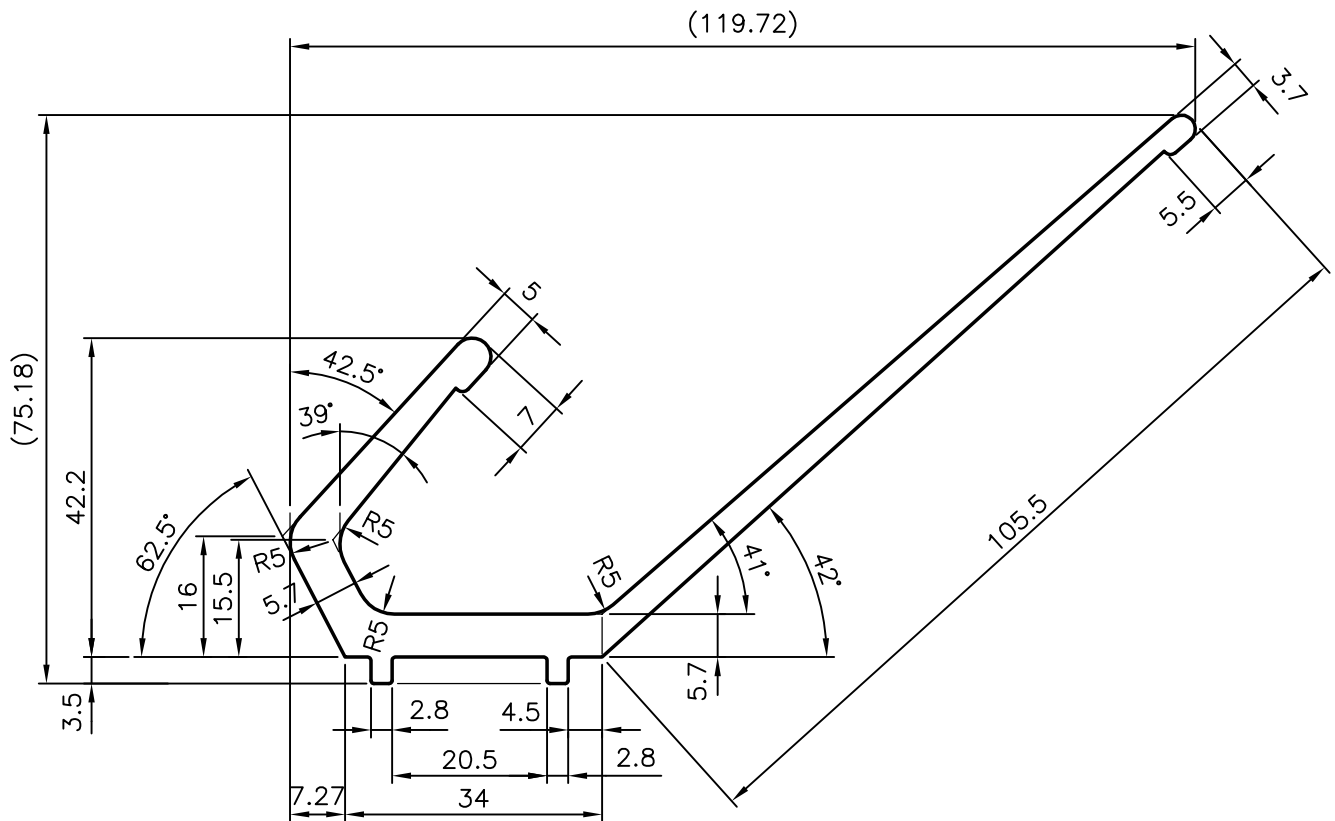

JINDAL ALUMINIUM LTD.
BANGALORE-560073 (INDIA)

	NAME	DATE
DRAWN	MALINGAPPA	10-09-2005
CHECKED		
APPROVED		

1. ALL DIMENSIONS ARE IN mm.
2. ROUND OFF ALL SHARP CORNERS WITH 0.40 mm.
3. TOLERANCES WILL BE AS PER IS:3965-1981 UNLESS OTHERWISE SPECIFIED

SCALE	1:1
AREA mm ²	800
PERIMETER mm.	387.384
WEIGHT kg/m	2.160

PARTY'S NAME	JINTAN INTERNATIONAL, NEW DELHI
PARTY'S DRAWING No.	AS PER SAMPLE
ALLOY & TEMPER	HE9 WP
DESCRIPTION	MISCELLANEOUS SECTION

DRAWING No.	SECTION No.
P-5862	-
S1590	S1590
28884	28884