

P-6112-1

S1687

28886

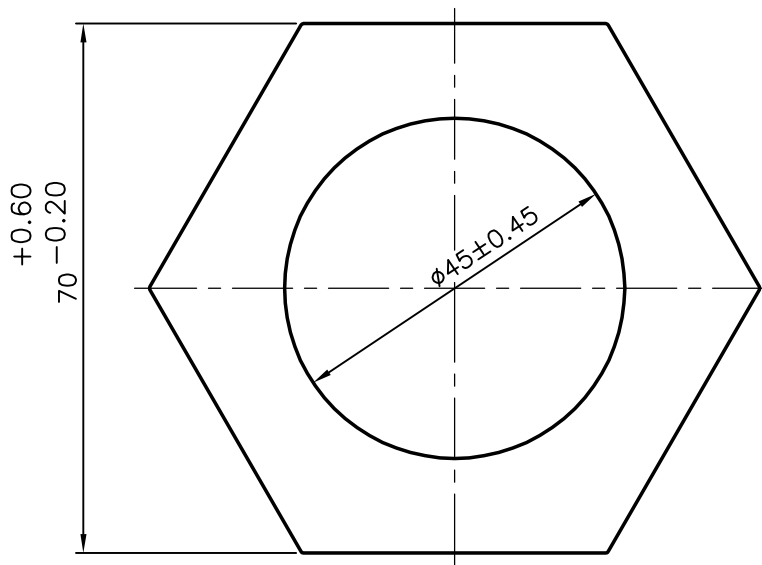

SYMBOL OF QUALITY  
AN ISO 9001 COMPANY

**JINDAL ALUMINIUM LTD.**  
BANGALORE-560073 (INDIA)

	NAME	DATE
DRAWN	MALINGAPPA	13-01-2006
CHECKED		
APPROVED		

1. ALL DIMENSIONS ARE IN mm.
2. ROUND OFF ALL SHARP CORNERS WITH 0.40 mm.
3. TOLERANCES WILL BE AS PER IS:6477-1983 UNLESS OTHERWISE SPECIFIED

SCALE	1:1
AREA mm <sup>2</sup>	2653.042
PERIMETER mm.	242.229
WEIGHT kg/m	7.163

PARTY'S NAME	BRITISH ENGINES (INDIA) PVT. LTD., BANGALORE
PARTY'S DRAWING No.	AS PER SPECIFICATION
ALLOY & TEMPER	6082 T6
DESCRIPTION	HEXAGONAL TUBE

DRAWING No.	SECTION No.
P-6112-1	-
S1687	S1687
28886	28886