

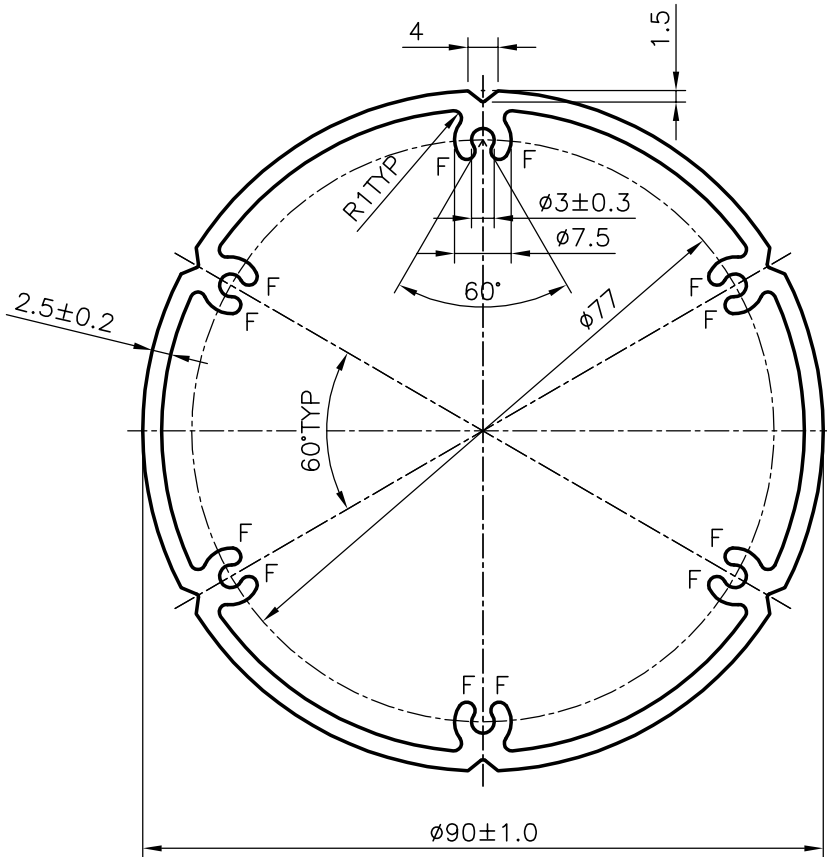

P-4991
S1266
X366
28897



F = FULL RADIUS (12 PLACES)

 SYMBOL OF QUALITY AN ISO 9002 COMPANY	JINDAL ALUMINIUM LTD. BANGALORE-560073 (INDIA)	NAME		DATE
		DRAWN	RAGHAVENDRA	23-07-2004
1. ALL DIMENSIONS ARE IN mm. 2. ROUND OFF ALL SHARP CORNERS WITH 0.40 mm. 3. TOLERANCES WILL BE AS PER IS:6477-1983 UNLESS OTHERWISE SPECIFIED		CHECKED		
		APPROVED		
PARTY'S NAME TWINKLE INDUSTRIES, DELHI		SCALE		1:1
		AREA mm ²		869.815
PARTY'S DRAWING No. AS PER DRAWING		PERIMETER mm.		288.629
		WEIGHT kg/m		2.348
ALLOY & TEMPER HE9 WP		DRAWING No.	SECTION No.	
		P-4991	-	
DESCRIPTION INDUSTRIAL MISC. SECTION		S1266	S1266	
		X366	X366	
		28897	28897	