

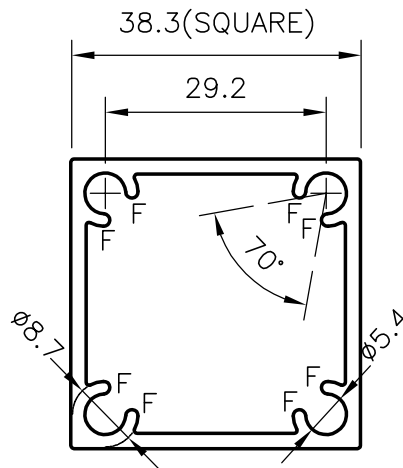

P-6079-1

28907



GENERAL WALL THICKNESS 2.0 mm

F= FULL RADIUS x 8 PLACE

 SYMBOL OF QUALITY AN ISO 9001 COMPANY	JINDAL ALUMINIUM LTD. BANGALORE-560073 (INDIA)	NAME		DATE
		DRAWN	J.P.KAUSHIK	04-01-2006
1. ALL DIMENSIONS ARE IN mm. 2. ROUND OFF ALL SHARP CORNERS WITH 0.40 mm. 3. TOLERANCES WILL BE AS PER COMMERCIAL UNLESS OTHERWISE SPECIFIED		CHECKED		
		APPROVED		
PARTY'S NAME PROSOURCE INDUSTRIAL SOLUTIONS,CANADA		SCALE		1:1
		AREA mm ²		337.474
PARTY'S DRAWING No. AS PER SAMPLE		PERIMETER mm.		152.513
		WEIGHT kg/m		0.911
ALLOY & TEMPER 6063 T5		DRAWING No.		SECTION No.
		P-6079-1		-
DESCRIPTION MISC. SECTION		28907		28907