

P-6714-1

28913

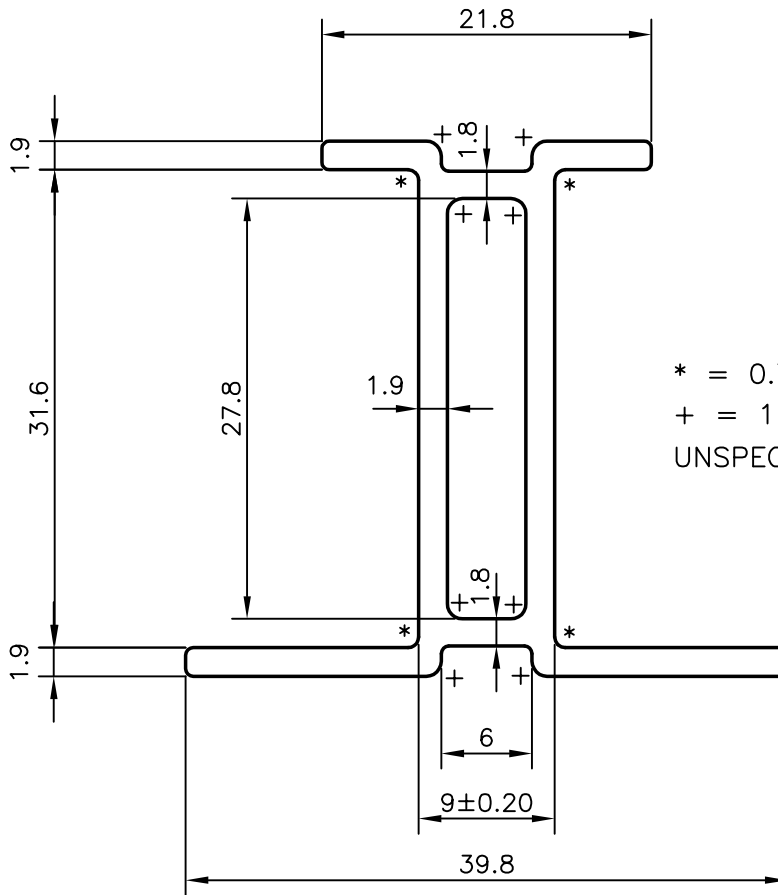

* = 0.70 RADIUS (4)
 + = 1.0 RADIUS (8)
 UNSPECIFIED RADII 0.50 mm.

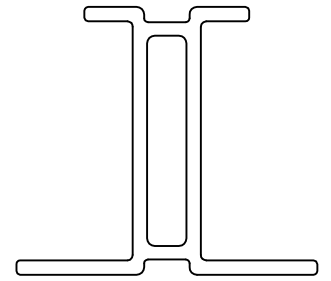

SYMBOL OF QUALITY
 AN ISO 9001 COMPANY

JINDAL ALUMINIUM LTD.
 BANGALORE-560073 (INDIA)

	NAME	DATE
DRAWN	J.P.KAUSHIK	30-10-2006
CHECKED		
APPROVED		
SCALE		2:1
AREA mm ²		233.086
PERIMETER mm.		178.506
WEIGHT kg/m		0.629
DRAWING No.	SECTION No.	
P-6714-1	-	
28913	28913	

1. ALL DIMENSIONS ARE IN mm.
2. ROUND OFF ALL SHARP CORNERS WITH 0.40 mm.
3. TOLERANCES WILL BE AS PER IS:6477-1983 UNLESS OTHERWISE SPECIFIED

PARTY'S NAME	DAN PAL (INDIA) PVT. LTD., NEW DELHI
PARTY'S DRAWING No.	AS PER SAMPLE
ALLOY & TEMPER	6063 T6
DESCRIPTION	MISC. SECTION