

P-6715-1

28914

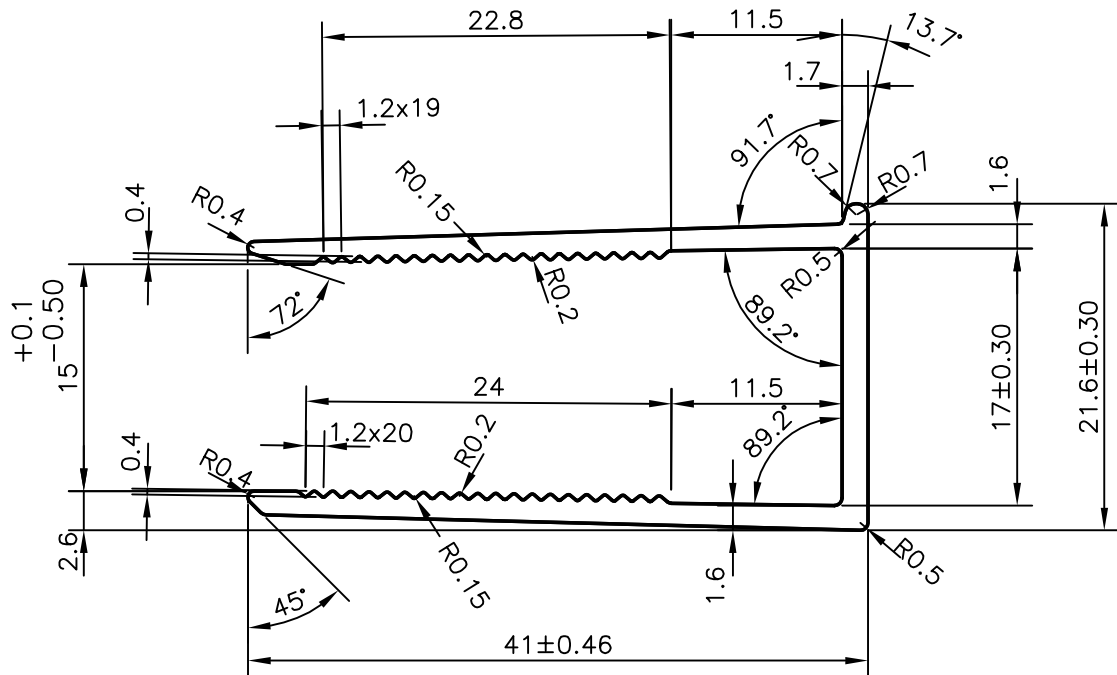
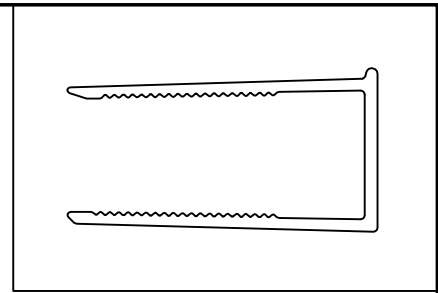

SYMBOL OF QUALITY  
AN ISO 9001 COMPANY

**JINDAL ALUMINIUM LTD.**  
BANGALORE-560073 (INDIA)

	NAME	DATE
DRAWN	J.P.KAUSHIK	01-11-2006
CHECKED		
APPROVED		

1. ALL DIMENSIONS ARE IN mm.
2. ROUND OFF ALL SHARP CORNERS WITH 0.40 mm.
3. TOLERANCES WILL BE AS PER IS:3965-1981 UNLESS OTHERWISE SPECIFIED

SCALE	2:1
AREA mm <sup>2</sup>	156.812
PERIMETER mm.	211.398
WEIGHT kg/m	0.423

PARTY'S NAME	DAN PAL (INDIA) PVT. LTD., NEW DELHI	DRAWING No.	P-6715-1	SECTION No.	-
PARTY'S DRAWING No.	AS PER DRAWING		28914		28914
ALLOY & TEMPER	6063 T6				
DESCRIPTION	MISC. CHANNEL				