

P-5124
S1350
28932

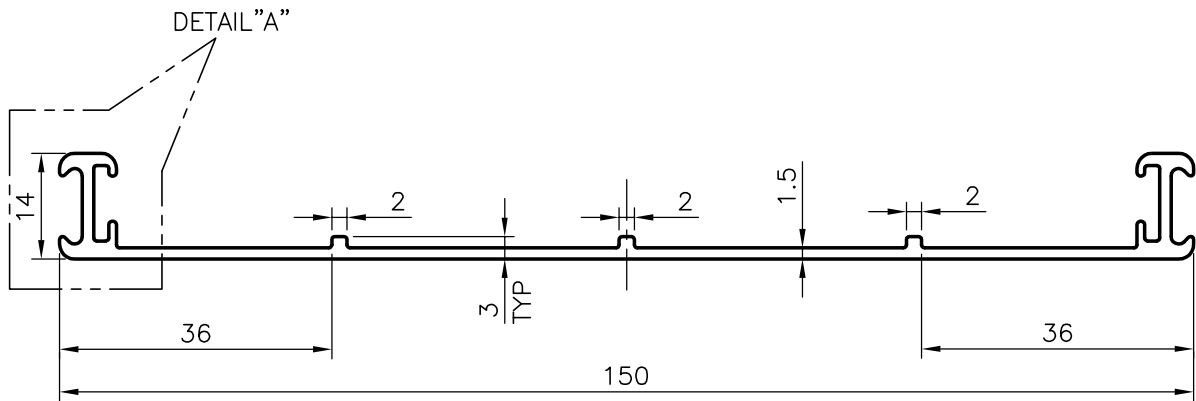
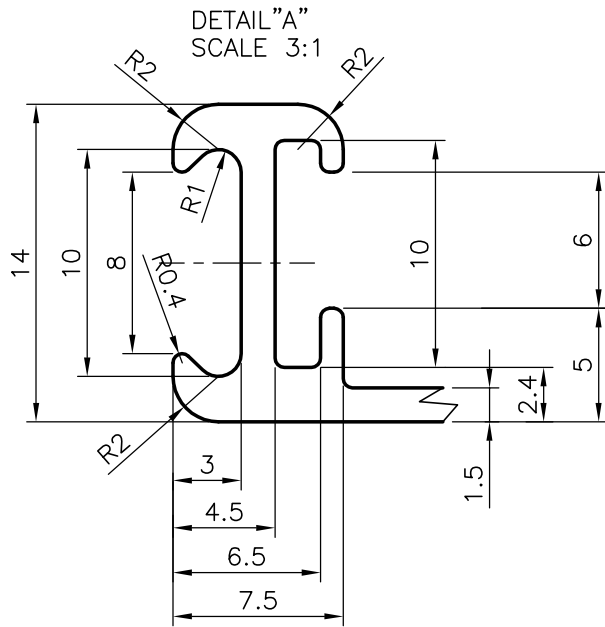

JINDAL ALUMINIUM LTD.
BANGALORE-560073 (INDIA)

	NAME	DATE
DRAWN	RAGHAVENDRA	05-11-2004
CHECKED		
APPROVED		

1. ALL DIMENSIONS ARE IN mm.
2. ROUND OFF ALL SHARP CORNERS WITH 0.40 mm.
3. TOLERANCES WILL BE AS PER IS:3965-1981 UNLESS OTHERWISE SPECIFIED

SCALE	1:1
AREA mm ²	309.521
PERIMETER mm.	394.688
WEIGHT kg/m	0.836

PARTY'S NAME	M.N.RAMA RAO & CO., BANGALORE
PARTY'S DRAWING No.	FRPF-RS150-01-3
ALLOY & TEMPER	HE9 WP
DESCRIPTION	INDUSTRIAL MISC. SECTION

DRAWING No.	SECTION No.
P-5124	-
S1350	S1350
28932	28932