

P-7333

28977

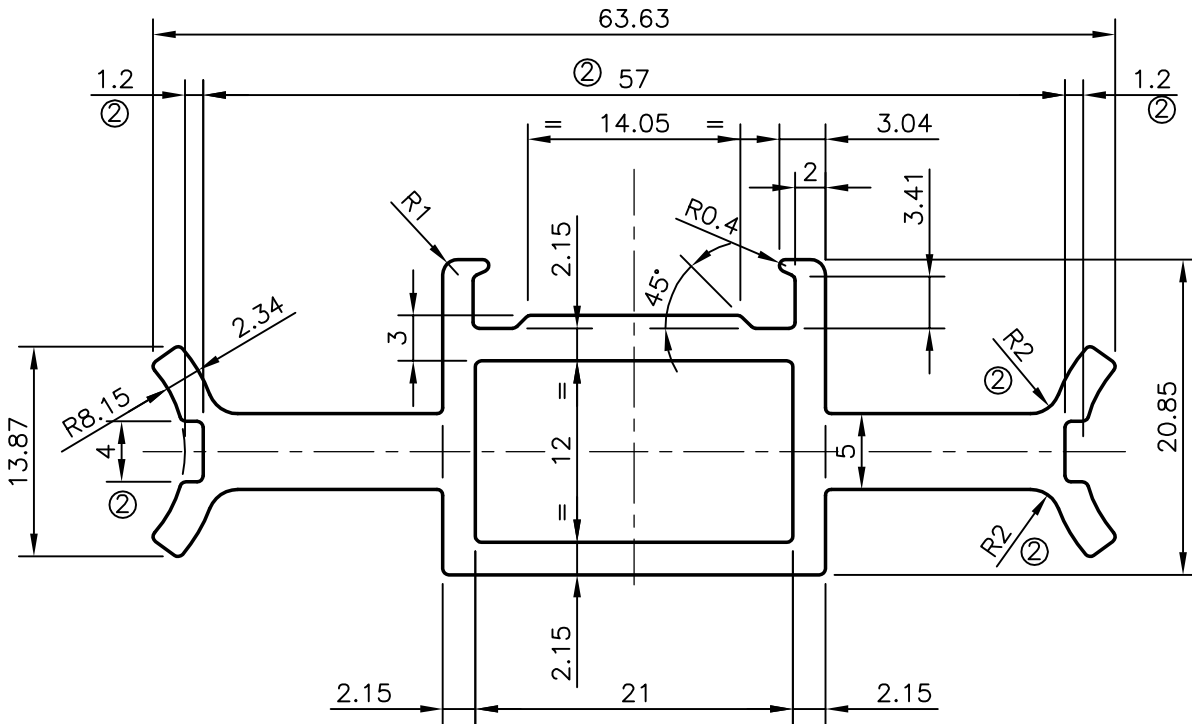

ISSUE- ② DIMENSION CHANGED FROM 3.20 mm TO 4.00 mm, 1.18 mm TO 1.20 mm, 57.68 mm TO 57.00 mm, RADIUS CHANGED FROM R0.4 mm TO R2.0 mm AND WEIGHT ALSO CHANGED FROM 1.079 kg/M TO 1.074 kg/M & THIS SECTION MATCH WITH SECTION NO-X702-ISSUE-2

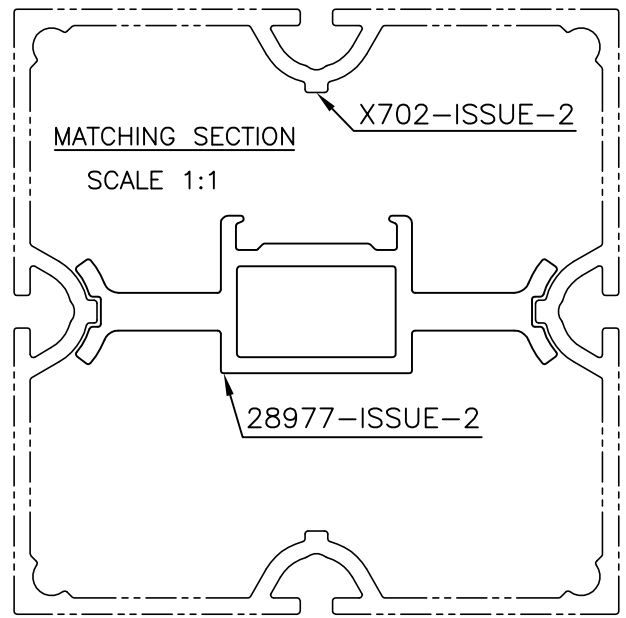

SYMBOL OF QUALITY  
AN ISO 9001 COMPANY

**JINDAL ALUMINIUM LTD.**  
BANGALORE-560073 (INDIA)

	NAME	DATE
DRAWN	PRASANN.H	27-06-2007
CHECKED		
APPROVED		
SCALE		2:1
AREA mm <sup>2</sup>		397.826
PERIMETER mm.		209.885
WEIGHT kg/m		1.074 ②
DRAWING No.	SECTION No.	
P-7333	-	
28977	28977-ISSUE-2	

1. ALL DIMENSIONS ARE IN mm.
2. ROUND OFF ALL SHARP CORNERS WITH 0.40 mm.
3. TOLERANCES WILL BE AS PER IS:6477-1983 UNLESS OTHERWISE SPECIFIED

PARTY'S NAME	GENERAL CATEGORY, DELHI MARKET
PARTY'S DRAWING No.	AS PER DRAWING
ALLOY & TEMPER	HE9 WP
DESCRIPTION	MISC. PROFILE