

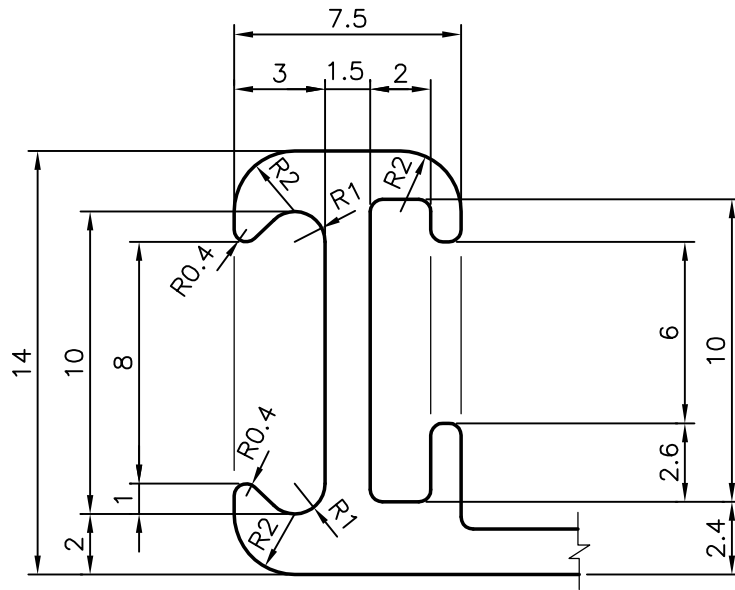

P-5580-1
S1525
29009

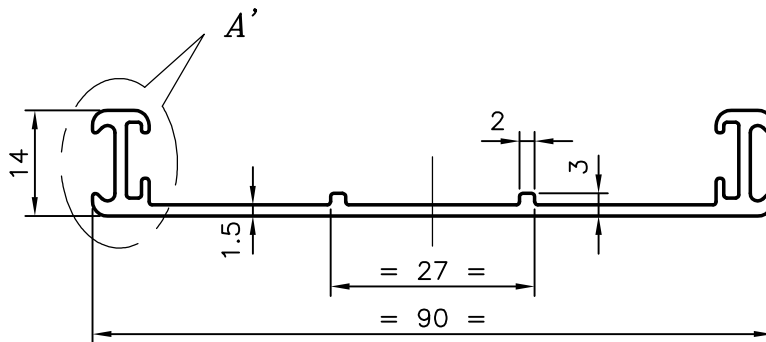

DETAIL-A

SCALE:- 4:1



 SYMBOL OF QUALITY AN ISO 9001 COMPANY	JINDAL ALUMINIUM LTD. BANGALORE-560073 (INDIA)	NAME		DATE
		DRAWN	MALINGAPPA	21-06-2005
1. ALL DIMENSIONS ARE IN mm. 2. ROUND OFF ALL SHARP CORNERS WITH 0.40 mm. 3. TOLERANCES WILL BE AS PER IS:3965-1981 UNLESS OTHERWISE SPECIFIED		CHECKED		
		APPROVED		
PARTY'S NAME M.N. RAMA RAO & COMPANY, BANGALORE		SCALE		1:1
		AREA mm ²		216.521
PARTY'S DRAWING No. FRPF-RS90-01-4		PERIMETER mm.		272.375
		WEIGHT kg/m		0.585
ALLOY & TEMPER HE9 WP		DRAWING No.		P-5580-1
		SECTION No.		-
DESCRIPTION FRAME PROFILE-RS90		S1525		S1525
		29009		29009