

P-7584-1

29023

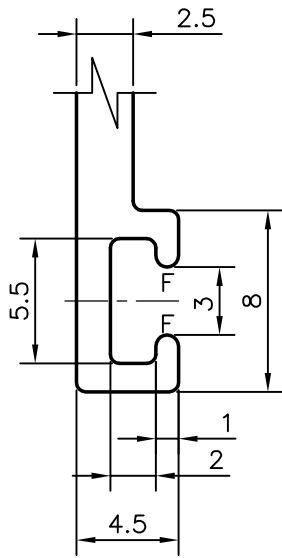

DETAIL OF "A"
SCALE 3:1

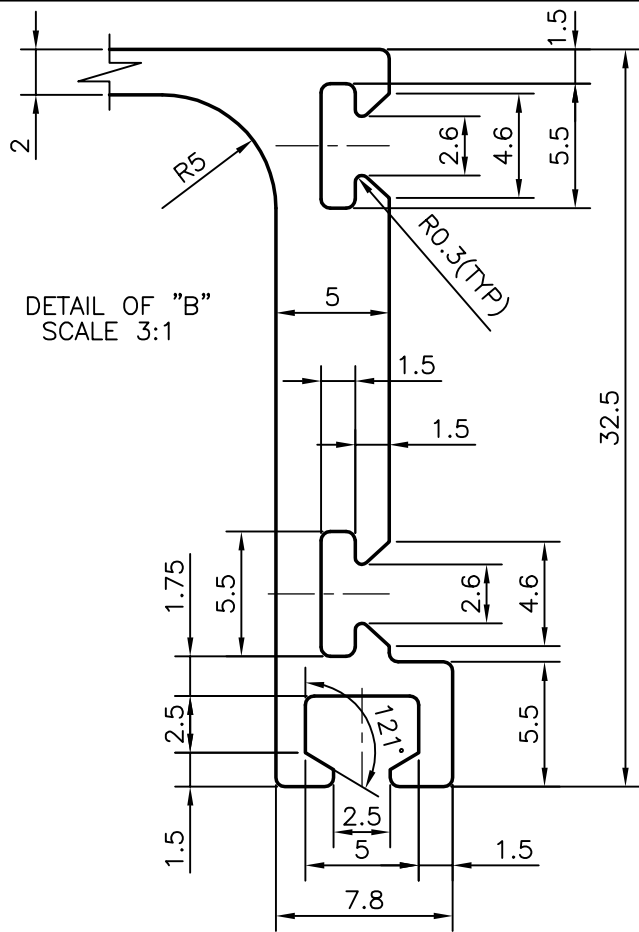

DETAIL OF "B"
SCALE 3:1

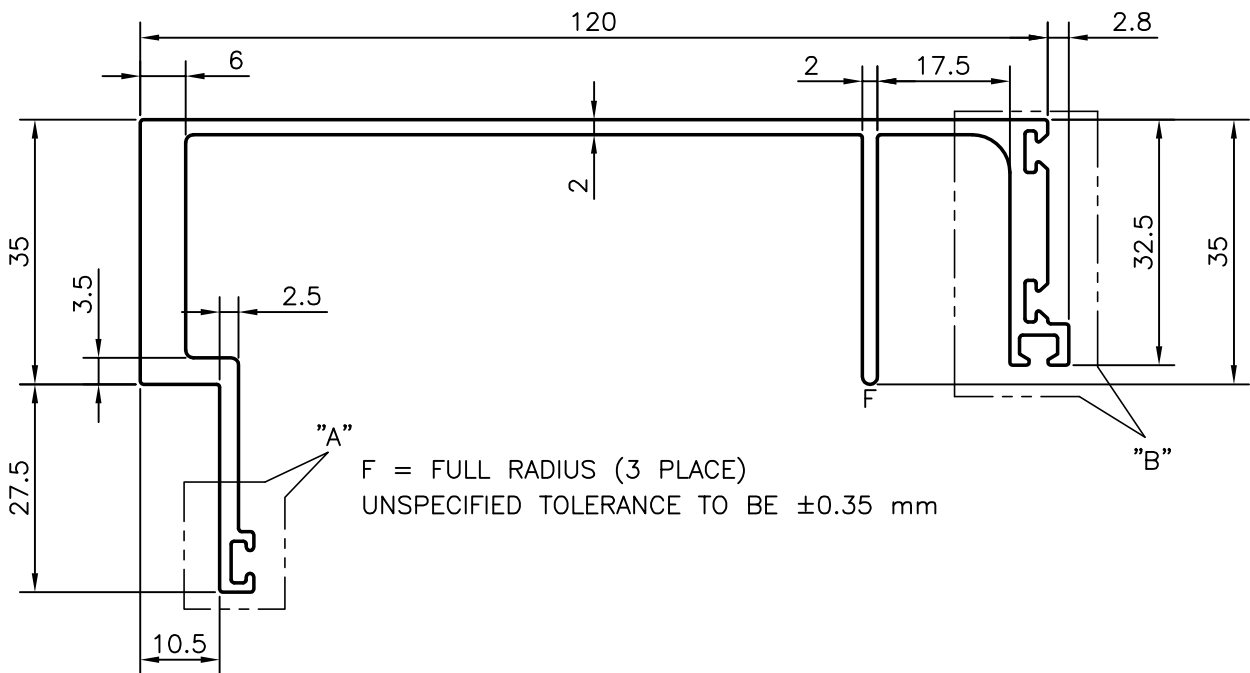

F = FULL RADIUS (3 PLACE)
UNSPECIFIED TOLERANCE TO BE ± 0.35 mm



SYMBOL OF QUALITY
AN ISO 9001 COMPANY

JINDAL ALUMINIUM LTD.
BANGALORE-560073 (INDIA)

	NAME	DATE
DRAWN	PRASANN.H	25-10-2007
CHECKED		
APPROVED		
SCALE		1:1
AREA mm ²		728.623
PERIMETER mm.		548.819
WEIGHT kg/m		1.967
DRAWING No.	SECTION No.	
P-7584-1	-	
29023	29023	

1. ALL DIMENSIONS ARE IN mm.
2. ROUND OFF ALL SHARP CORNERS WITH 0.40 mm.
3. TOLERANCES WILL BE AS PER IS:3965-1981 UNLESS OTHERWISE SPECIFIED

PARTY'S NAME	GLASS WALL SYSTEMS, MUMBAI
PARTY'S DRAWING No.	GWS/P/GWS/D3
ALLOY & TEMPER	HE9 WP
DESCRIPTION	ST. GLAZING MALE MULLION