

P-7589-1

29026

DETAIL OF "C"
SCALE 3:1

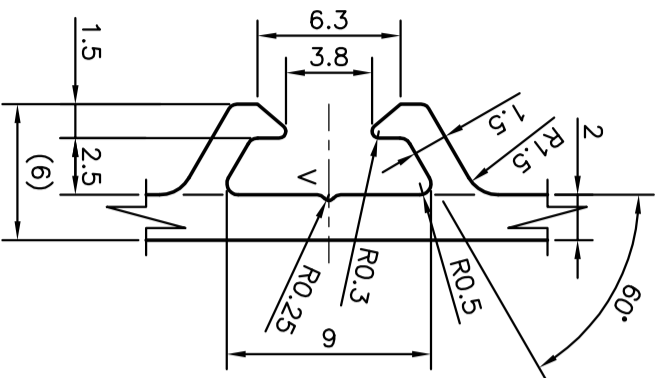

DETAIL OF "A"
SCALE 3:1

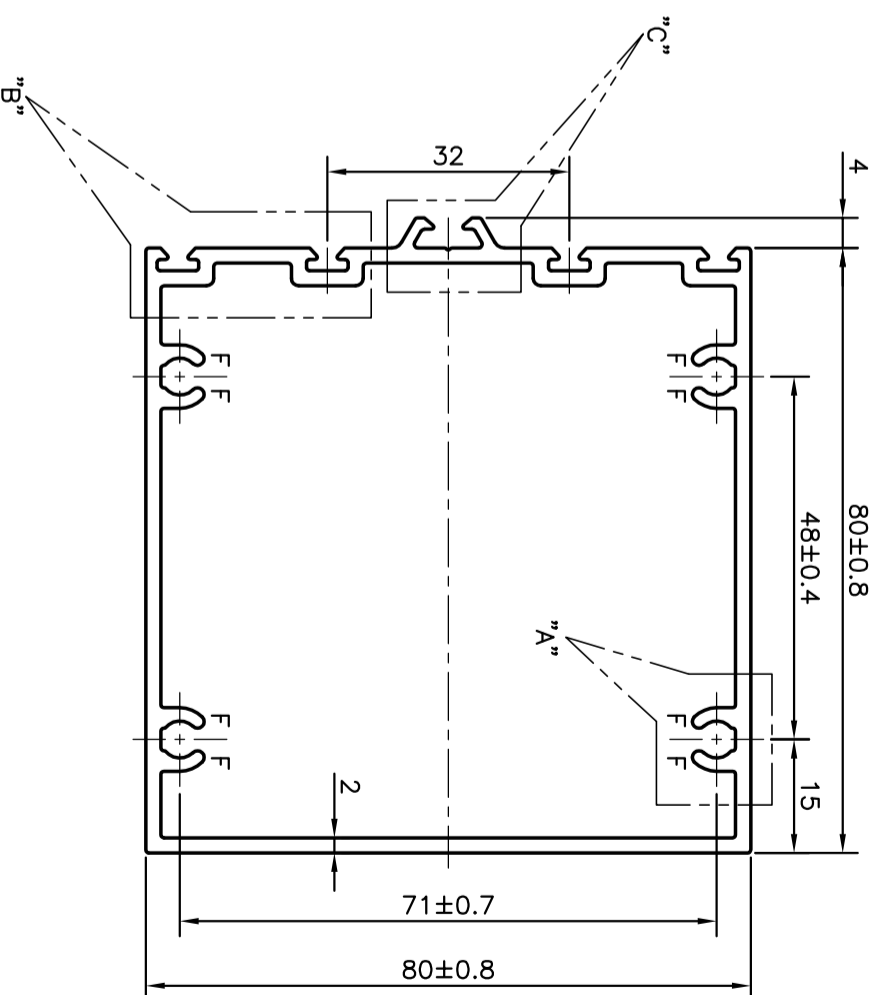
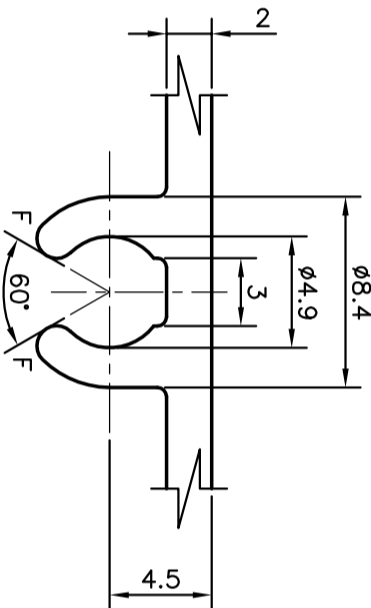

F = FULL RADIUS (8 PLACES)
V = 0.25x90° 'V' GROOVE (1 PLACE)
UNSPECIFIED TOLERANCE TO BE ±0.35 mm

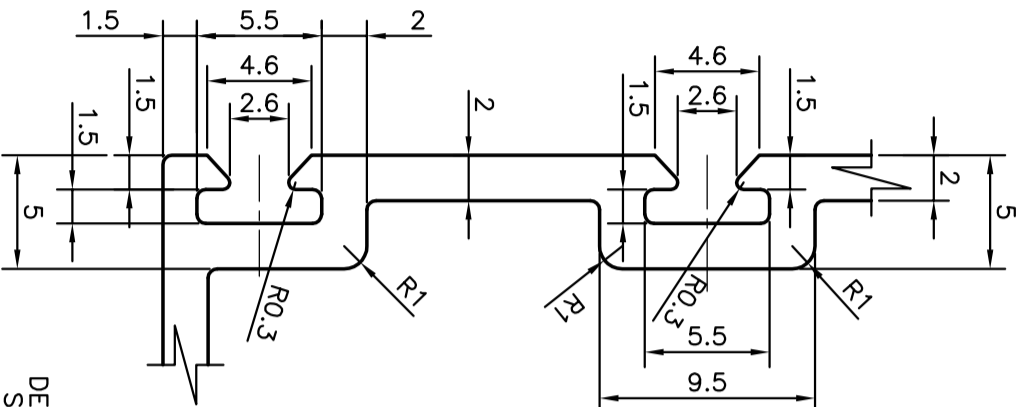

DETAIL OF "B"
SCALE 3:1

 <p>SYMBOL OF QUALITY AN ISO 9001 COMPANY</p>		<p>JINDAL ALUMINIUM LTD. BANGALORE-560073 (INDIA)</p>		NAME	DATE
				DRAWN	PRASANN. H
PARTY'S NAME		GLASS WALL SYSTEMS, MUMBAI		CHECKED	
PARTY'S DRAWING No.		GWS/P/RN/D1		APPROVED	
ALLOY & TEMPER		HE9 WP		SCALE	1:1
DESCRIPTION		ST. GLAZING TRANSOM SECTION		AREA mm ²	775.852
				PERIMETER mm.	376.782
				WEIGHT kg/m	2.095
				DRAWING No.	SECTION No.
				P-7589-1	-
				29026	29026