

P-7660

29055

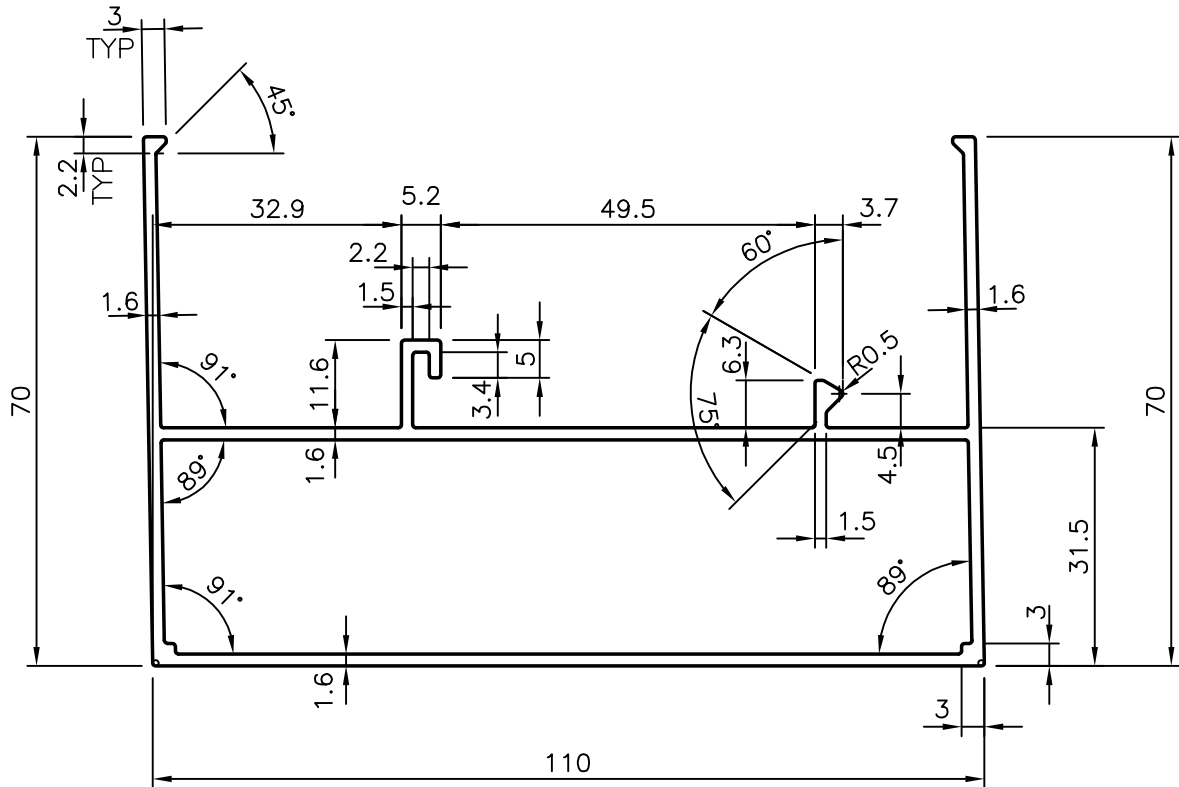
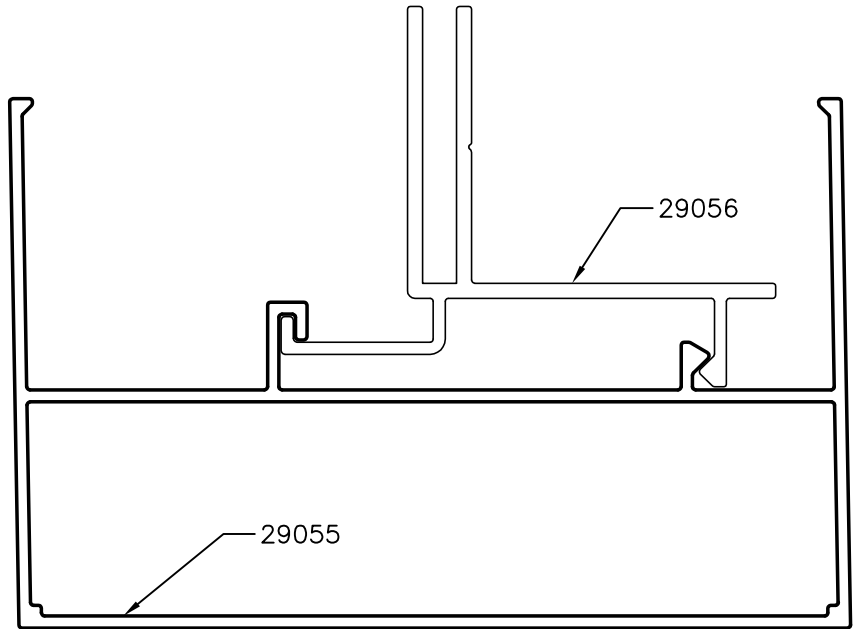

SYMBOL OF QUALITY
AN ISO 9001 COMPANY

JINDAL ALUMINIUM LTD.
BANGALORE-560073 (INDIA)

	NAME	DATE
DRAWN	J.P.KAUSHIK	13-11-2007
CHECKED		
APPROVED		
SCALE		1:1
AREA mm ²		616.637
PERIMETER mm.		489.531
WEIGHT kg/m		1.665
DRAWING No.	SECTION No.	
P-7660	-	
29055	29055	

1. ALL DIMENSIONS ARE IN mm.
2. ROUND OFF ALL SHARP CORNERS WITH 0.40 mm.
3. TOLERANCES WILL BE AS PER IS:6477-1983 UNLESS OTHERWISE SPECIFIED

PARTY'S NAME	SP FABRICATORS PVT LTD.,MUMBAI
PARTY'S DRAWING No.	AL-380
ALLOY & TEMPER	6063 T6
DESCRIPTION	HORIZONTAL CAPPING PROFILE