

P-7702

29060

DETAIL OF "A"  
SCALE 5:1

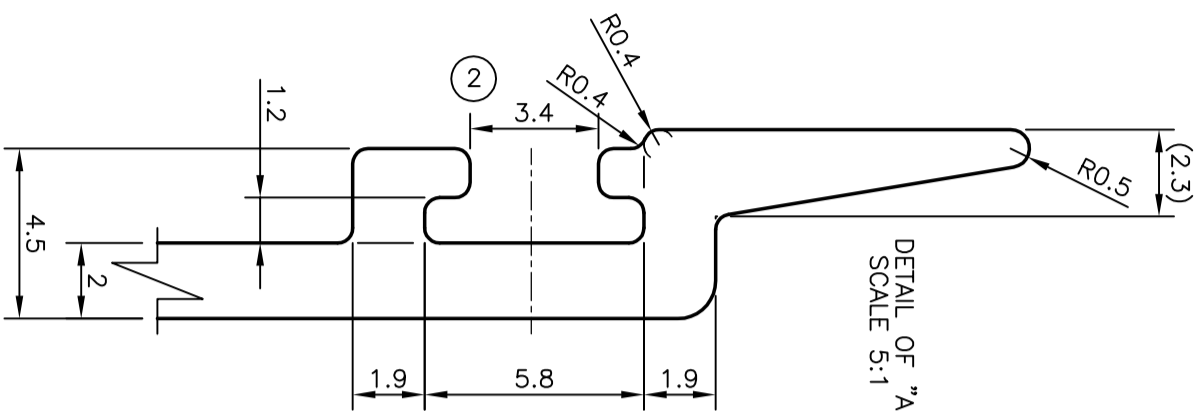

ISSUE - 2  
DIMENSION CHANGED FROM 3.60 mm TO 3.40 mm

SCALE 1:1

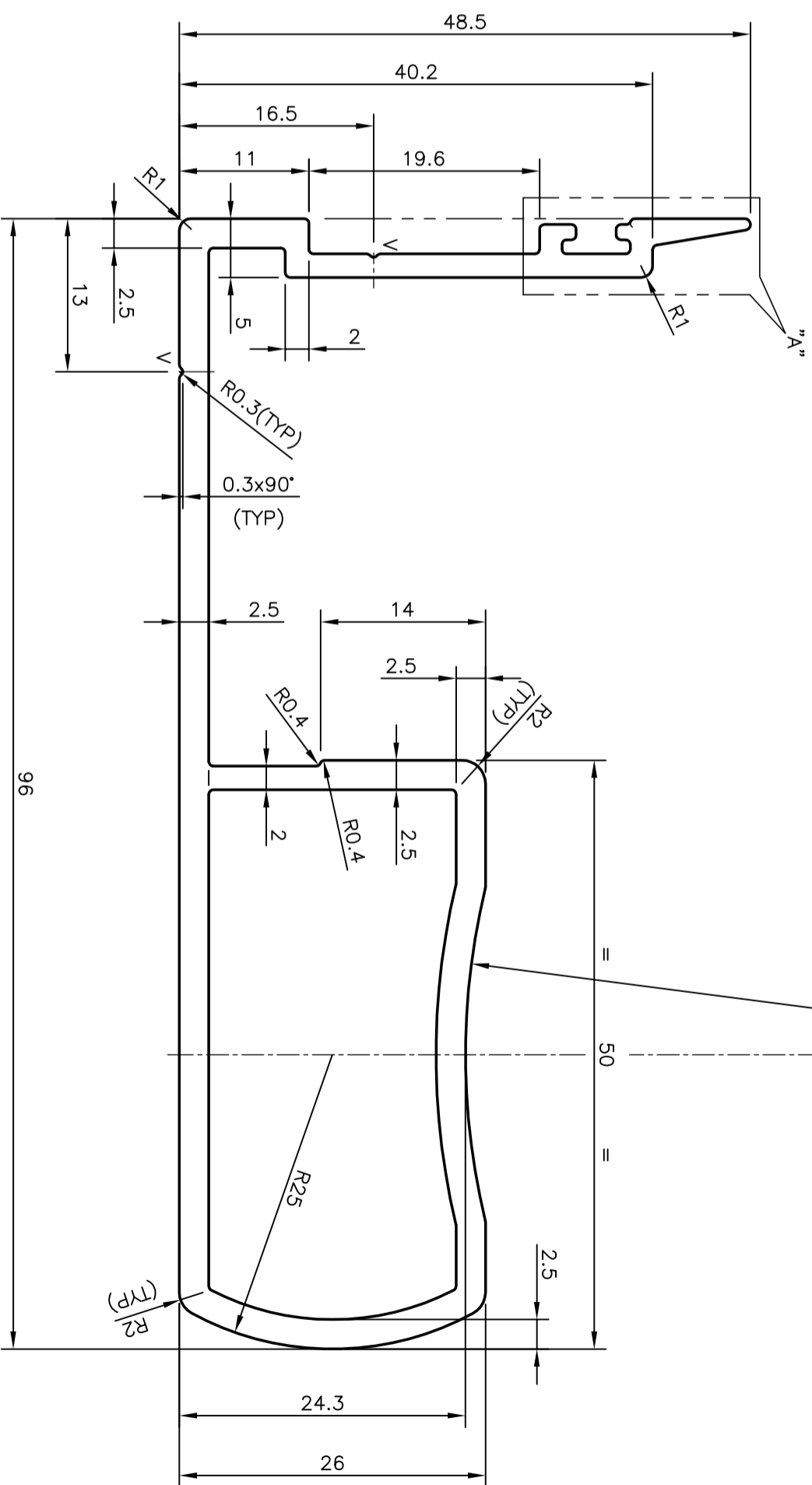
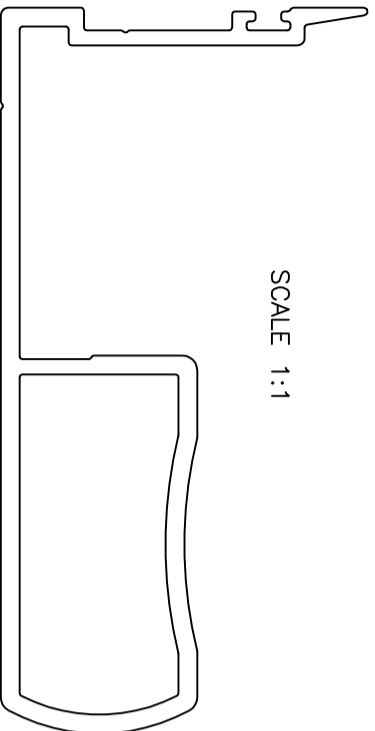

V = V'-GROOVE 0.3x90° ( 2 PLACES)

 SYMBOL OF QUALITY AN ISO 9001 COMPANY	<b>JINDAL ALUMINIUM LTD.</b> BANGALORE-560073 (INDIA)		DRAWN PRASANNAH	NAME PRASANNAH	DATE 14-06-2008
	1. ALL DIMENSIONS ARE IN mm. 2. ROUND OFF ALL SHARP CORNERS WITH 0.40 mm. 3. TOLERANCES WILL BE AS PER IS:6477-1983 UNLESS OTHERWISE SPECIFIED		CHECKED  APPROVED		
PARTY'S NAME B.L.KASHYAP & SONS LTD., BANGALORE	PARTY'S DRAWING No. AS PER SAMPLE	SCALE 2:1	AREA mm <sup>2</sup> 562.691		
ALLOY & TEMPER HE9 WP	PARTY'S NAME B.L.KASHYAP & SONS LTD., BANGALORE	PERIMETER mm. 345.28	WEIGHT kg/m 1.519		
DESCRIPTION MISC. SECTION	DRAWING No. P-7702	SECTION No. -	DRAWING No. 29060	SECTION No. 29060-ISSUE-2	