

P-5855

S1589

29062

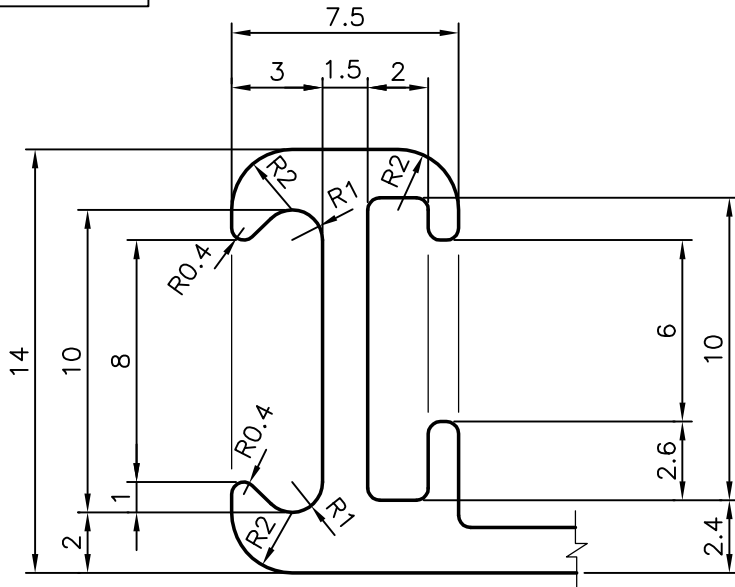

**DETAIL-A**

SCALE:- 4:1

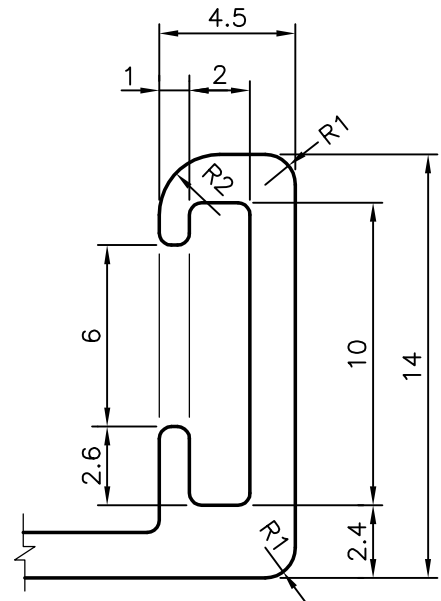

**DETAIL-B**

SCALE:- 4:1

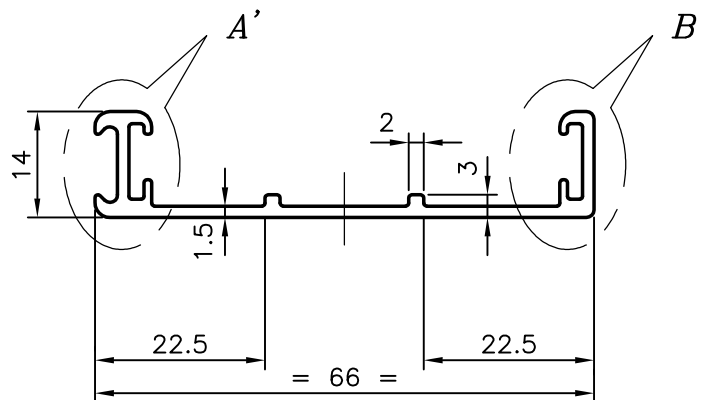

SYMBOL OF QUALITY  
AN ISO 9001 COMPANY

**JINDAL ALUMINIUM LTD.**  
BANGALORE-560073 (INDIA)

	NAME	DATE
DRAWN	MALINGAPPA	08-09-2005
CHECKED		
APPROVED		
SCALE		1:1
AREA mm <sup>2</sup>		171.757
PERIMETER mm.		217.739
WEIGHT kg/m		0.464
DRAWING No.	SECTION No.	
P-5855	-	
S1589	S1589	
29062	29062	

1. ALL DIMENSIONS ARE IN mm.
2. ROUND OFF ALL SHARP CORNERS WITH 0.40 mm.
3. TOLERANCES WILL BE AS PER IS:3965-1981 UNLESS OTHERWISE SPECIFIED

PARTY'S NAME M.N. RAMA RAO & COMPANY, BANGALORE

PARTY'S DRAWING No. FRPF-RS66-01-4

ALLOY & TEMPER HE9 WP

DESCRIPTION FRAME PROFILE-RS66