

P-7902

29098

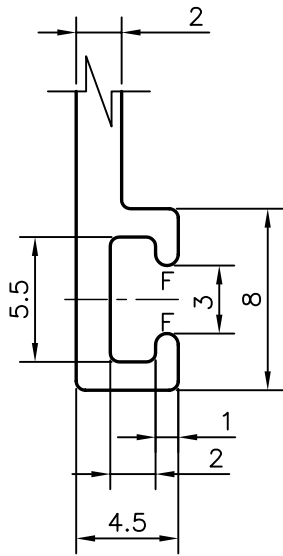

DETAIL OF "A"
SCALE 3:1

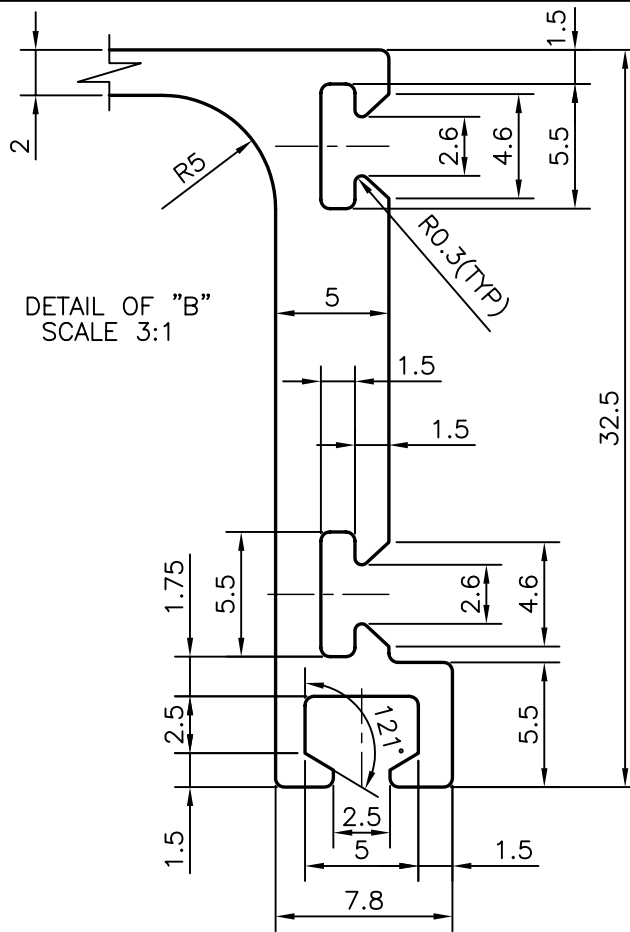

DETAIL OF "B"
SCALE 3:1

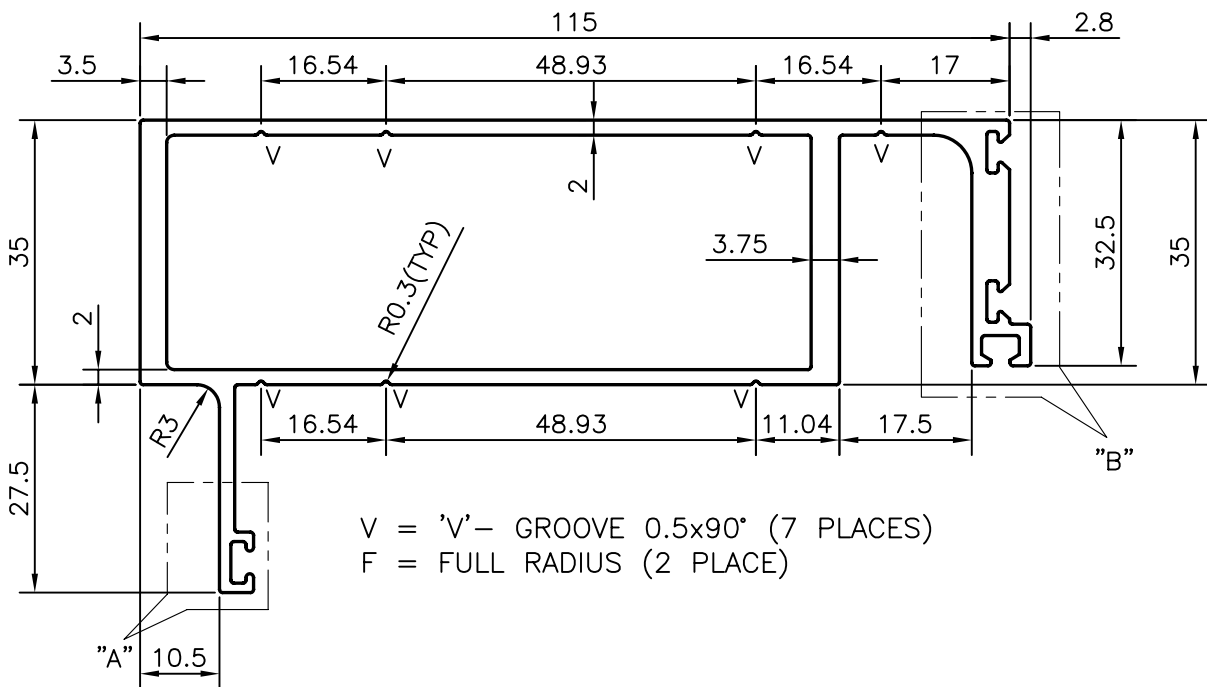

V = 'V'- GROOVE 0.5x90° (7 PLACES)
F = FULL RADIUS (2 PLACE)



SYMBOL OF QUALITY
AN ISO 9001 COMPANY

JINDAL ALUMINIUM LTD.
BANGALORE-560073 (INDIA)

	NAME	DATE
DRAWN	PRASANNA.H	12-02-2008
CHECKED		
APPROVED		
SCALE		1:1
AREA mm ²		830.057
PERIMETER mm.		462.094
WEIGHT kg/m		2.241
DRAWING No.	SECTION No.	
P-7902	-	
29098	29098	

1. ALL DIMENSIONS ARE IN mm.
2. ROUND OFF ALL SHARP CORNERS WITH 0.40 mm.
3. TOLERANCES WILL BE AS PER IS:6477-1983 UNLESS OTHERWISE SPECIFIED

PARTY'S NAME	GLASS WALL SYSTEMS, MUMBAI
PARTY'S DRAWING No.	GWS/P/HCC/D2
ALLOY & TEMPER	HE9 WP
DESCRIPTION	ST. GLAZING MALE MULLION