

P-7903

29099

DETAIL OF "C"  
SCALE 3:1

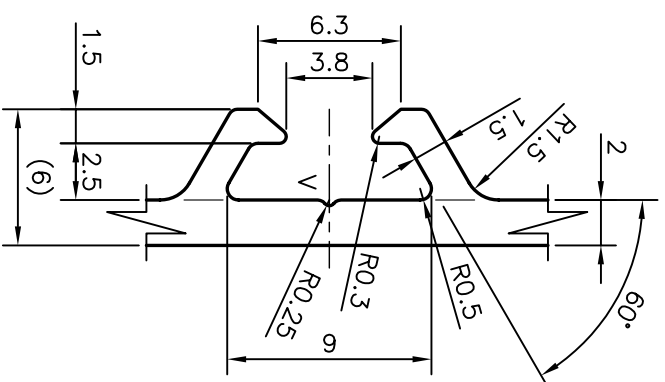

DETAIL OF "A"  
SCALE 3:1

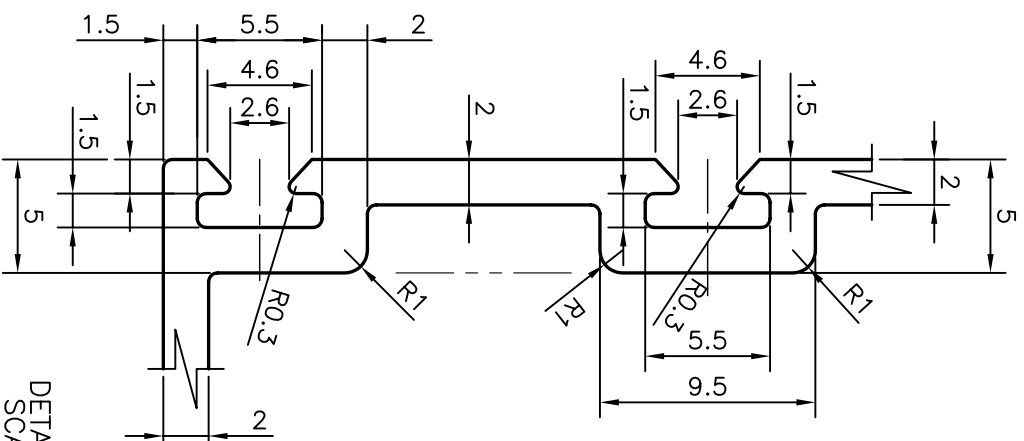
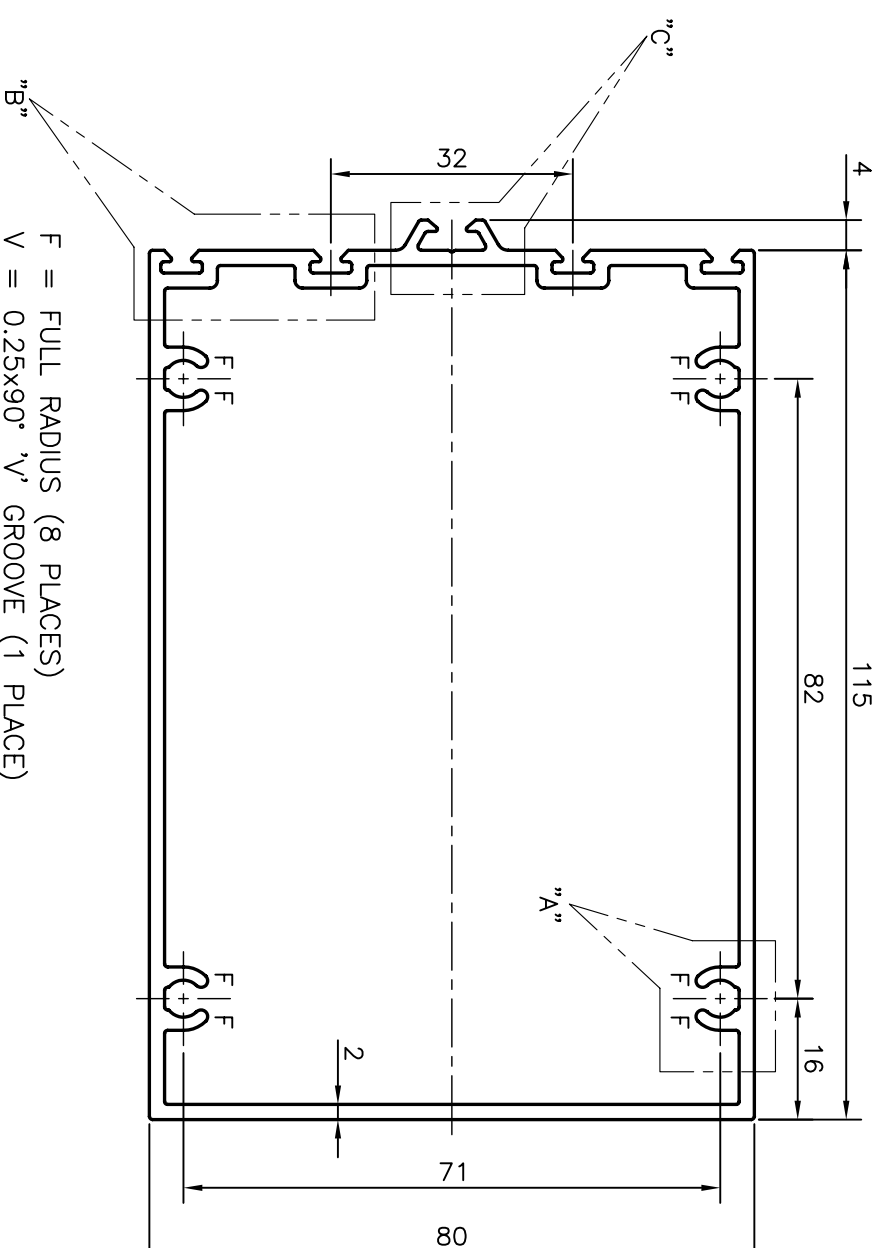
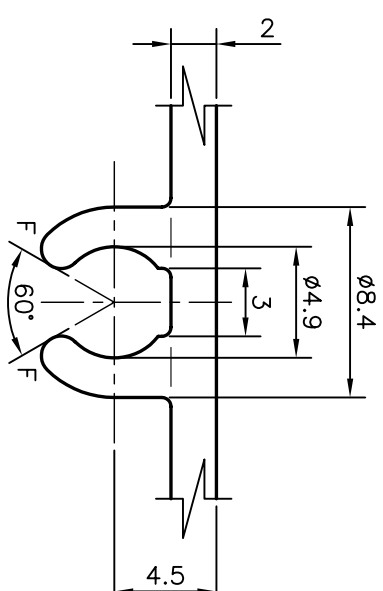

DETAIL OF "B"  
SCALE 3:1

 <p>SYMBOL OF QUALITY AN ISO 9001 COMPANY</p>	<p><b>JINDAL ALUMINIUM LTD.</b> BANGALORE-560073 (INDIA)</p>		NAME	DATE
	<p>1. ALL DIMENSIONS ARE IN mm. 2. ROUND OFF ALL SHARP CORNERS WITH 0.40 mm. 3. TOLERANCES WILL BE AS PER IS:6477-1983 UNLESS OTHERWISE SPECIFIED</p>		DRAWN	PRASANNA.H
PARTY'S NAME	GLASS WALL SYSTEMS, MUMBAI		CHECKED	
PARTY'S DRAWING No.	GWS/P/HCC/D3		APPROVED	
ALLOY & TEMPER	HE9 WP		SCALE	1:1
DESCRIPTION	ST. GLAZING TRANSOM SECTION		AREA mm <sup>2</sup>	915.852
			PERIMETER mm.	446.782
			WEIGHT kg/m	2.473
			DRAWING No.	SECTION No.
			P-7903	-
			29099	29099