

P-7905

29101

DETAIL OF "B"
SCALE 3:1

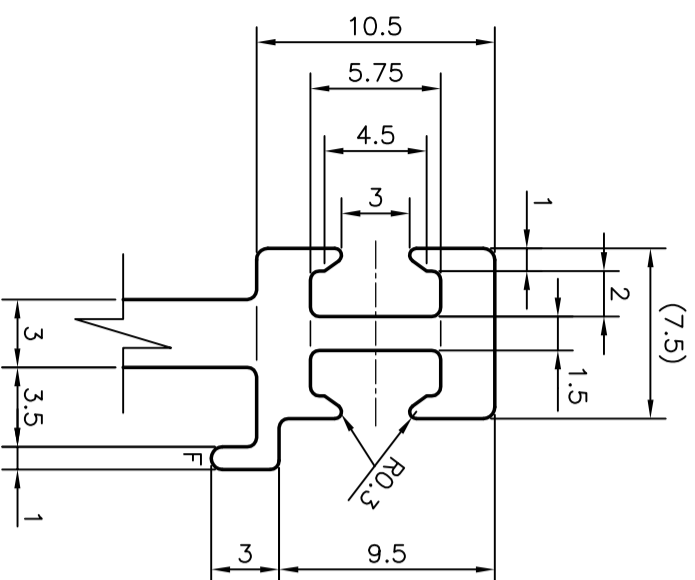

DETAIL OF "A"
SCALE 3:1

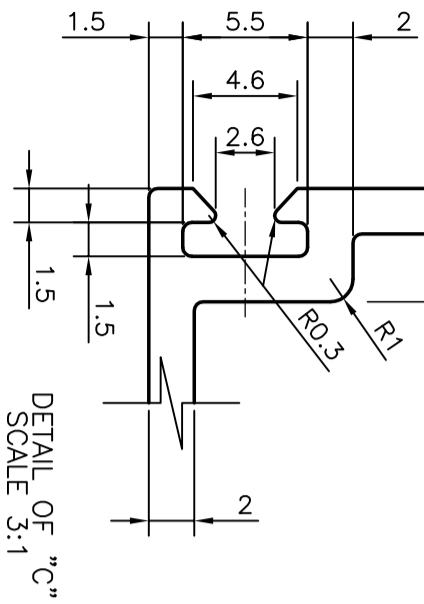
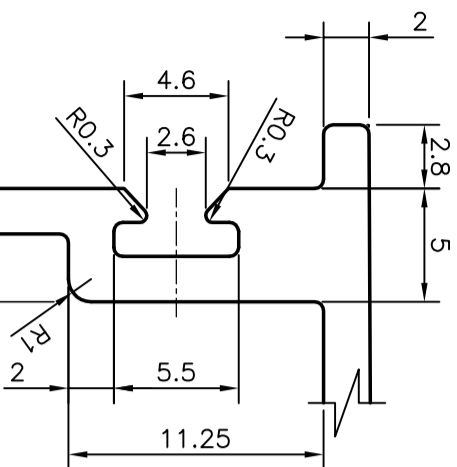
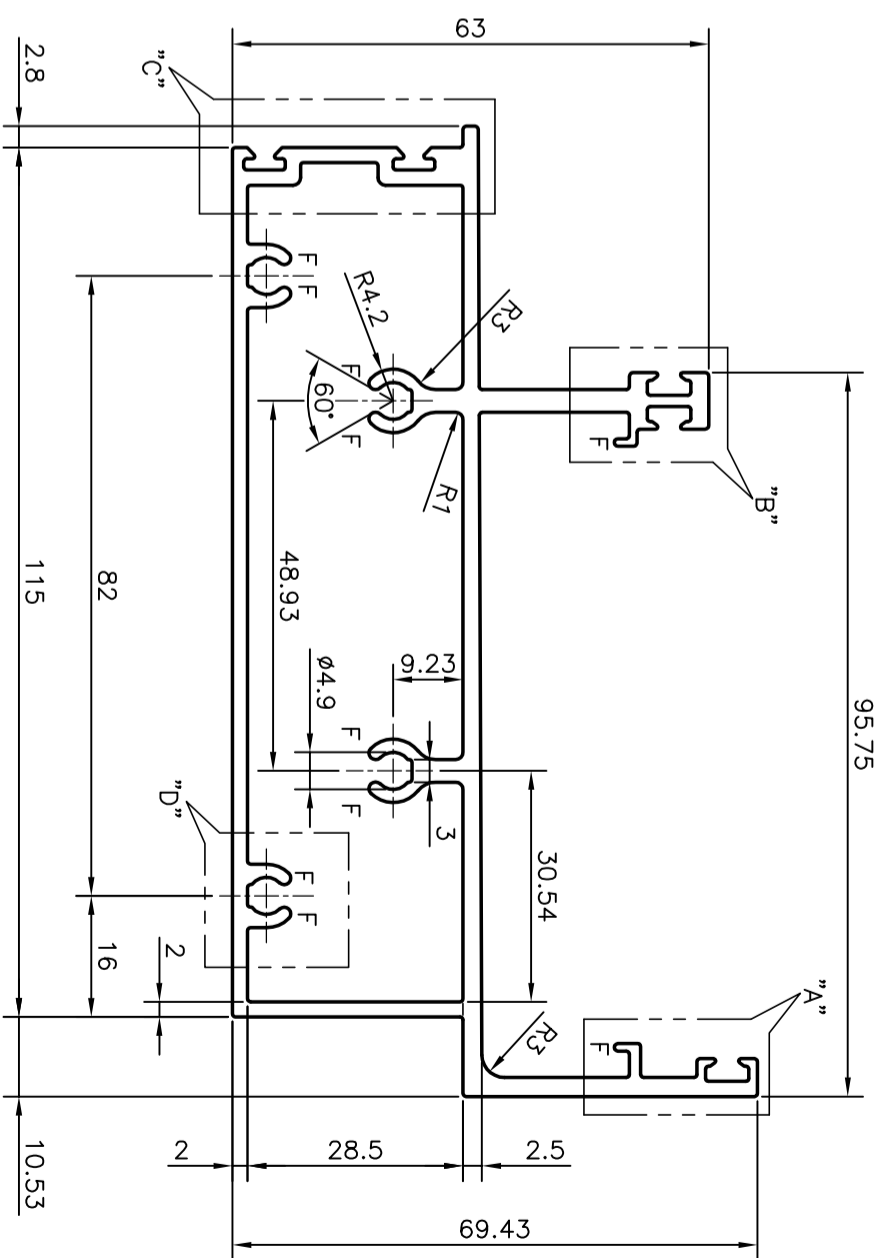
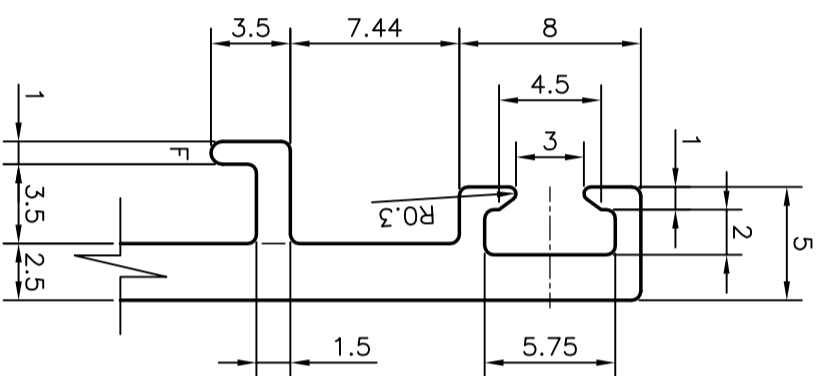

DETAIL OF "D"
SCALE 3:1

DETAIL OF "C"
SCALE 3:1

F = FULL RADIUS (10 PLACES)

 <p>SYMBOL OF QUALITY AN ISO 9001 COMPANY</p>		<p>JINDAL ALUMINIUM LTD. BANGALORE-560073 (INDIA)</p>		NAME	DATE
				DRAWN	PRASANNA.H
<p>1. ALL DIMENSIONS ARE IN mm. 2. ROUND OFF ALL SHARP CORNERS WITH 0.40 mm. 3. TOLERANCES WILL BE AS PER IS:6477-1983 UNLESS OTHERWISE SPECIFIED</p>		CHECKED			
		APPROVED			
PARTY'S NAME	GLASS WALL SYSTEMS, MUMBAI	SCALE	1:1		
PARTY'S DRAWING No.	GWS/P/HCC/D5	AREA mm ²	1018.607		
ALLOY & TEMPER	HE9 WP	PERIMETER mm.	533.209		
DESCRIPTION	ST. GLAZING GUTTER SECTION	WEIGHT kg/m	2.750		
		DRAWING No.	29101		
		SECTION No.	29101		