

P-7908

29103

SCALE 1:1

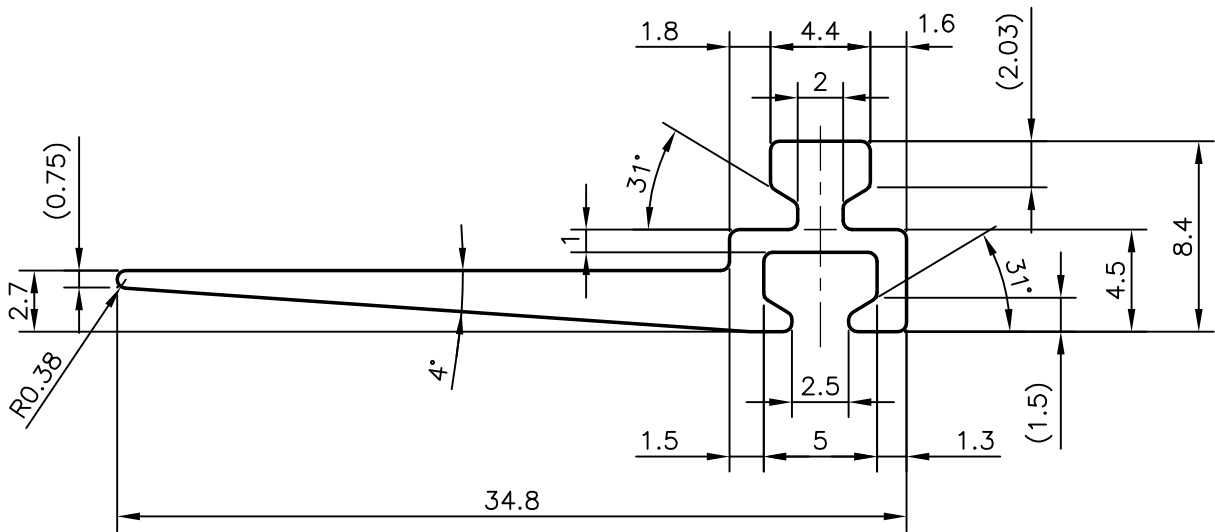

SYMBOL OF QUALITY  
AN ISO 9001 COMPANY

**JINDAL ALUMINIUM LTD.**  
BANGALORE-560073 (INDIA)

	NAME	DATE
DRAWN	PRASANNA.H	12-02-2008
CHECKED		
APPROVED		

1. ALL DIMENSIONS ARE IN mm.
2. ROUND OFF ALL SHARP CORNERS WITH 0.40 mm.
3. TOLERANCES WILL BE AS PER IS:3965-1981 UNLESS OTHERWISE SPECIFIED

SCALE	3:1
AREA mm <sup>2</sup>	79.532
PERIMETER mm.	96.504
WEIGHT kg/m	0.215

PARTY'S NAME GLASS WALL SYSTEMS, MUMBAI

PARTY'S DRAWING No. GWS/P/HCC/D8

ALLOY & TEMPER HE9 WP

DESCRIPTION MISC. SECTION

DRAWING No.	SECTION No.
P-7908	-
29103	29103