

P-7909

29104

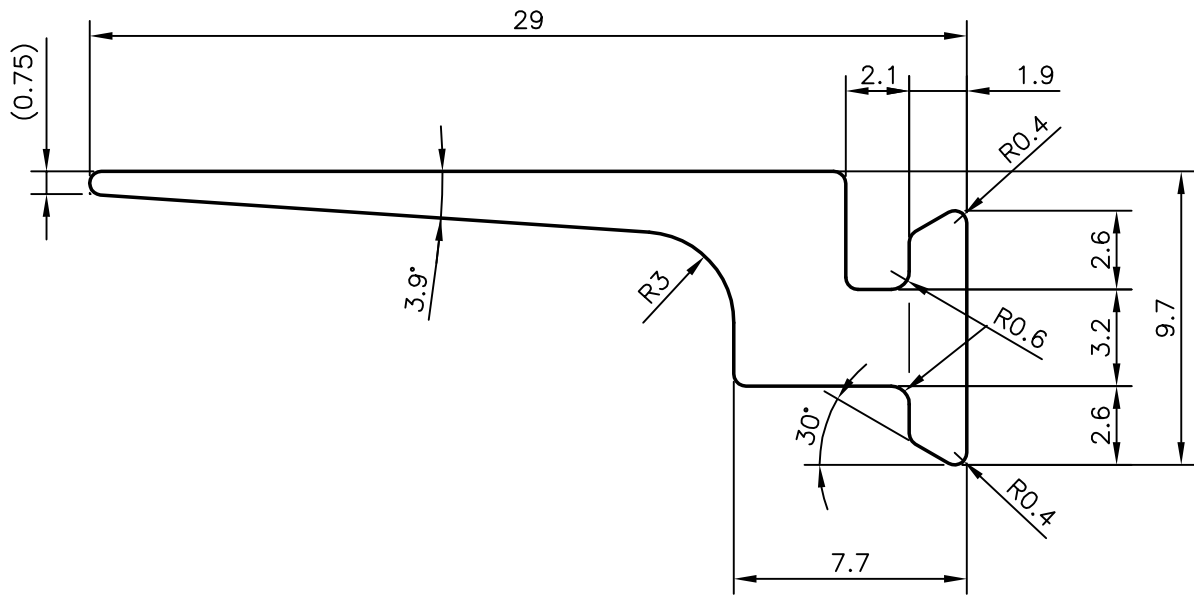

SYMBOL OF QUALITY  
AN ISO 9001 COMPANY

**JINDAL ALUMINIUM LTD.**  
BANGALORE-560073 (INDIA)

	NAME	DATE
DRAWN	PRASANNA.H	12-02-2008
CHECKED		
APPROVED		

1. ALL DIMENSIONS ARE IN mm.
2. ROUND OFF ALL SHARP CORNERS WITH 0.40 mm.
3. TOLERANCES WILL BE AS PER IS:3965-1981 UNLESS OTHERWISE SPECIFIED

SCALE	4:1
AREA mm <sup>2</sup>	80.89
PERIMETER mm.	77.152
WEIGHT kg/m	0.218

PARTY'S NAME: GLASS WALL SYSTEMS, MUMBAI

PARTY'S DRAWING No.: GWS/P/HCC/D9

ALLOY & TEMPER: HE9 WP

DESCRIPTION: MISC. SECTION

DRAWING No.	SECTION No.
P-7909	-
29104	29104