

P-7642-1

29117

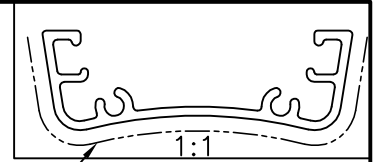

VISIBLE SURFACE

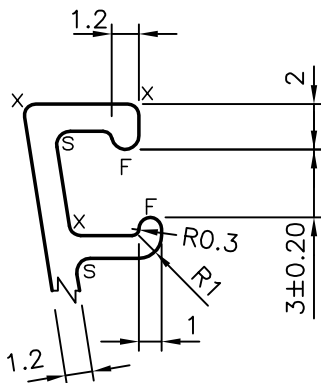
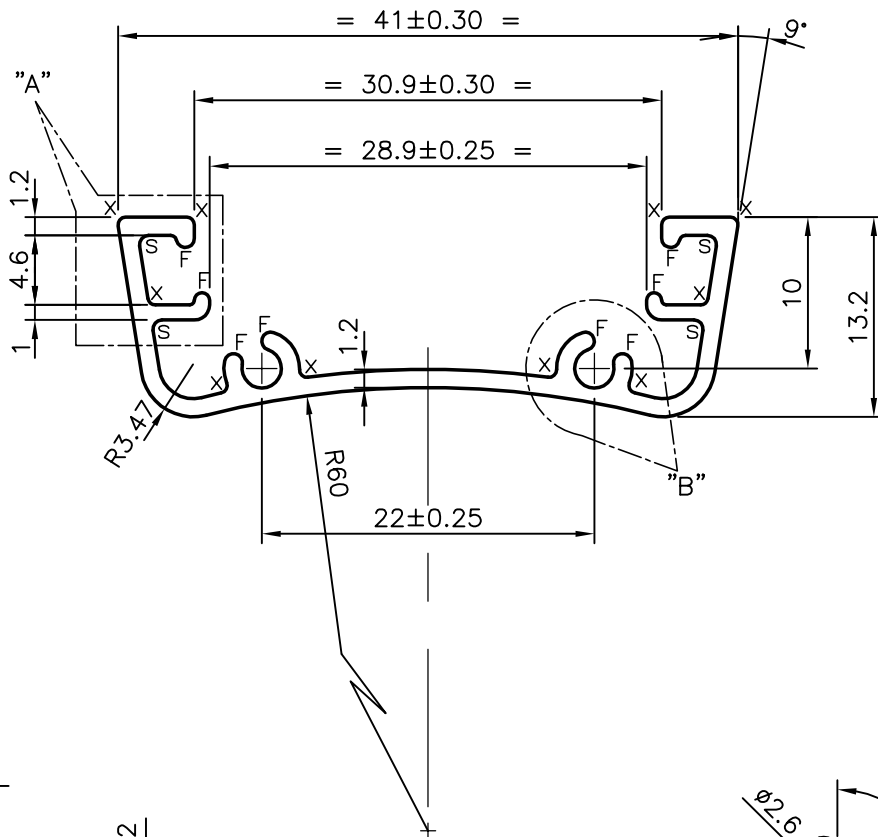

DETAIL OF "A"  
SCALE 3:1

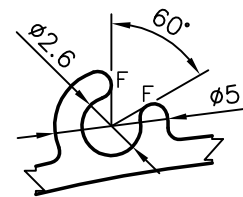

DETAIL OF "B"  
SCALE 3:1

NOTE:-

1. F = FULL RADIUS (8 PLACES)
2. s = R0.60 mm (4 PLACES)
3. x = R0.50 mm (10 PLACES)



SYMBOL OF QUALITY  
AN ISO 9001 COMPANY

**JINDAL ALUMINIUM LTD.**  
BANGALORE-560073 (INDIA)

	NAME	DATE
DRAWN	J.P.KAUSHIK	21-12-2007
CHECKED		
APPROVED		
SCALE		2:1
AREA mm <sup>2</sup>		106.322
PERIMETER mm.		174.497
WEIGHT kg/m		0.287
DRAWING No.	SECTION No.	
P-7642-1	-	
29117	29117	

1. ALL DIMENSIONS ARE IN mm.  
2. ROUND OFF ALL SHARP CORNERS WITH 0.40 mm.  
3. TOLERANCES WILL BE AS PER IS:3965-1981 UNLESS OTHERWISE SPECIFIED

PARTY'S NAME	N.B.T EXPORT PVT. LTD.,MUMBAI
PARTY'S DRAWING No.	30101-RA4A-0001
ALLOY & TEMPER	6063 T5
DESCRIPTION	MISC. SECTION