

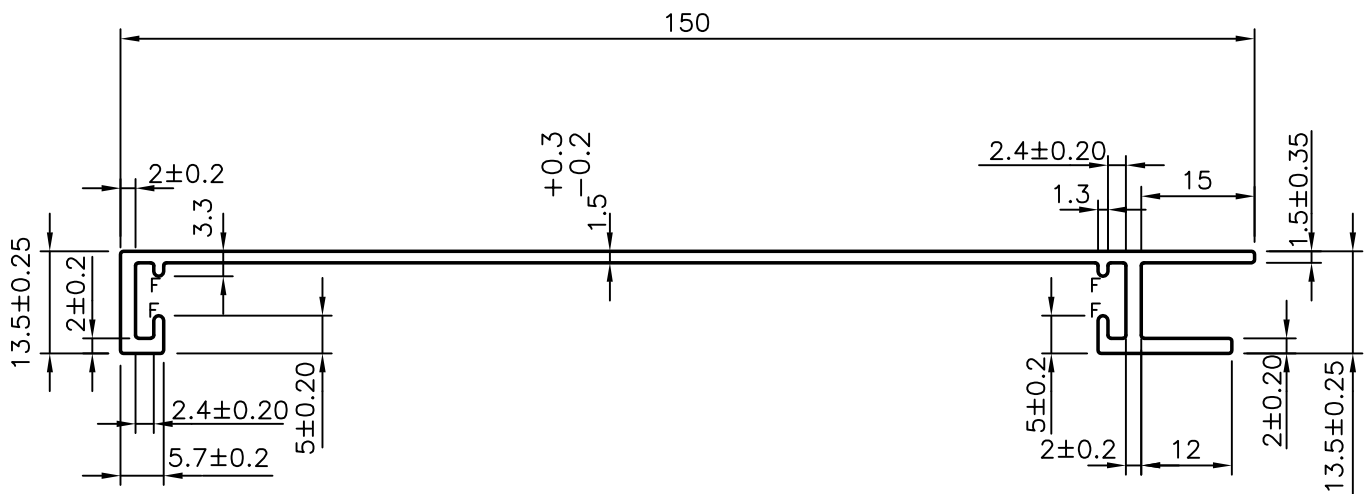

P-5994-2
S1679
29123



F = FULL RADIUS = (4 PLACES)

 SYMBOL OF QUALITY AN ISO 9001 COMPANY	JINDAL ALUMINIUM LTD. BANGALORE-560073 (INDIA)	NAME		DATE
		DRAWN	J.P.KAUSHIK	07-01-2006
1. ALL DIMENSIONS ARE IN mm. 2. ROUND OFF ALL SHARP CORNERS WITH 0.40 mm. 3. TOLERANCES WILL BE AS PER IS:3965-1981 UNLESS OTHERWISE SPECIFIED		CHECKED		
		APPROVED		
PARTY'S NAME DYNA FILTERS (P) LTD.,PUNE		SCALE		1:1
		AREA mm ²		323.692
PARTY'S DRAWING No. 728		PERIMETER mm.		403.335
		WEIGHT kg/m		0.874
ALLOY & TEMPER 6063 T6		DRAWING No.		SECTION No.
		P-5994-2		
DESCRIPTION MISC. CHANNEL		S1679		S1679
		29123		29123