

P-7063-1

S1980

29128

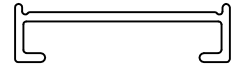

SCALE 1:1

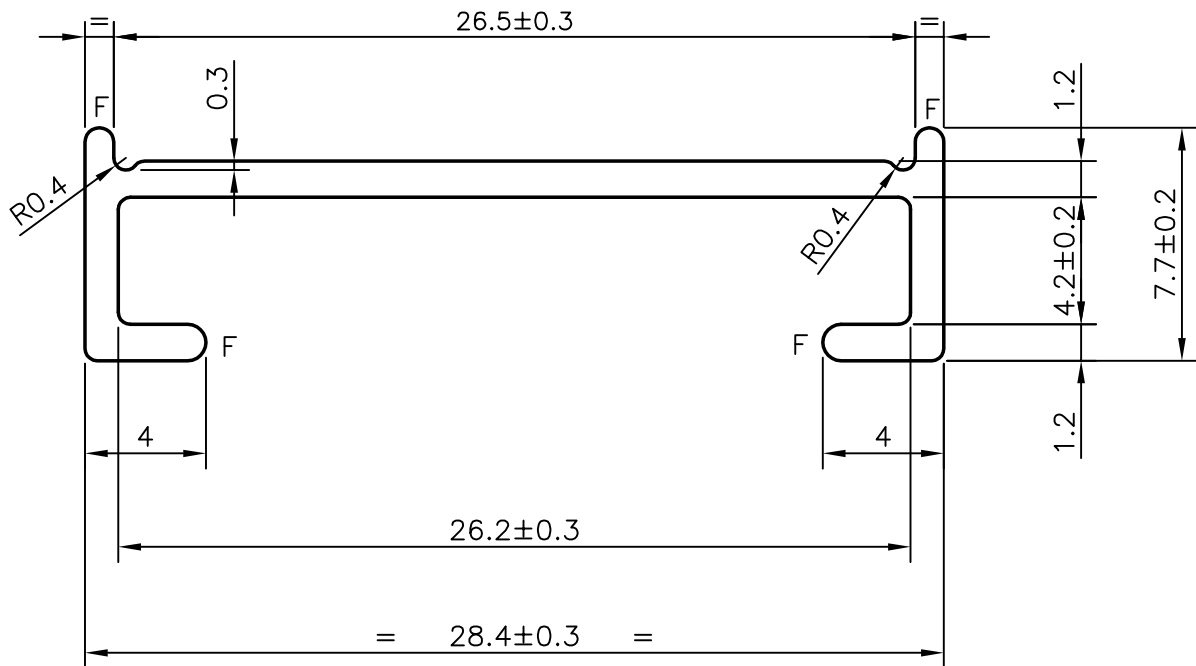

F= FULL RADIUS (4 PLACES)



SYMBOL OF QUALITY  
AN ISO 9002 COMPANY

**JINDAL ALUMINIUM LTD.**  
BANGALORE-560073 (INDIA)

	NAME	DATE
DRAWN	PRASANN. H	27-03-2007
CHECKED		
APPROVED		

1. ALL DIMENSIONS ARE IN mm.
2. ROUND OFF ALL SHARP CORNERS WITH 0.40 mm.
3. TOLERANCES WILL BE AS PER IS:3965-1981 UNLESS OTHERWISE SPECIFIED

SCALE	4:1
AREA mm <sup>2</sup>	54.217
PERIMETER mm.	94.365
WEIGHT kg/m	0.146

PARTY'S NAME INSTA EXHIBITION PVT LTD., MUMBAI

PARTY'S DRAWING No. AS PER DRAWING

ALLOY & TEMPER 6063 T6

DESCRIPTION MISC. SECTION

DRAWING No.	SECTION No.
P-7063-1	-
S1980	S1980
29128	29128