

P-6188

S1707

29142

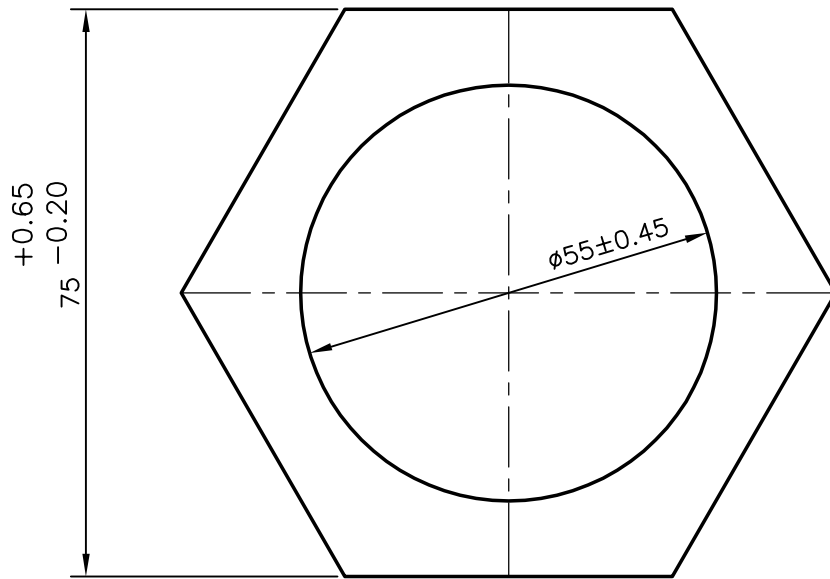

SYMBOL OF QUALITY
AN ISO 9001 COMPANY

JINDAL ALUMINIUM LTD.
BANGALORE-560073 (INDIA)

	NAME	DATE
DRAWN	J.P.KAUSHIK	11-02-2006
CHECKED		
APPROVED		
SCALE		1:1
AREA mm ²		2495.563
PERIMETER mm.		259.808
WEIGHT kg/m		6.738
DRAWING No.	SECTION No.	
P-6188	-	
S1707	S1707	
29142	29142	

1. ALL DIMENSIONS ARE IN mm.
2. ROUND OFF ALL SHARP CORNERS WITH 0.40 mm.
3. TOLERANCES WILL BE AS PER IS:6477-1983 UNLESS OTHERWISE SPECIFIED

PARTY'S NAME	BRITISH ENGINES (INDIA) PVT. LTD., BANGALORE
PARTY'S DRAWING No.	AS PER SPECIFICATION
ALLOY & TEMPER	6082 T6
DESCRIPTION	HEXAGONAL TUBE