

DETAIL OF "D"
SCALE 3:1

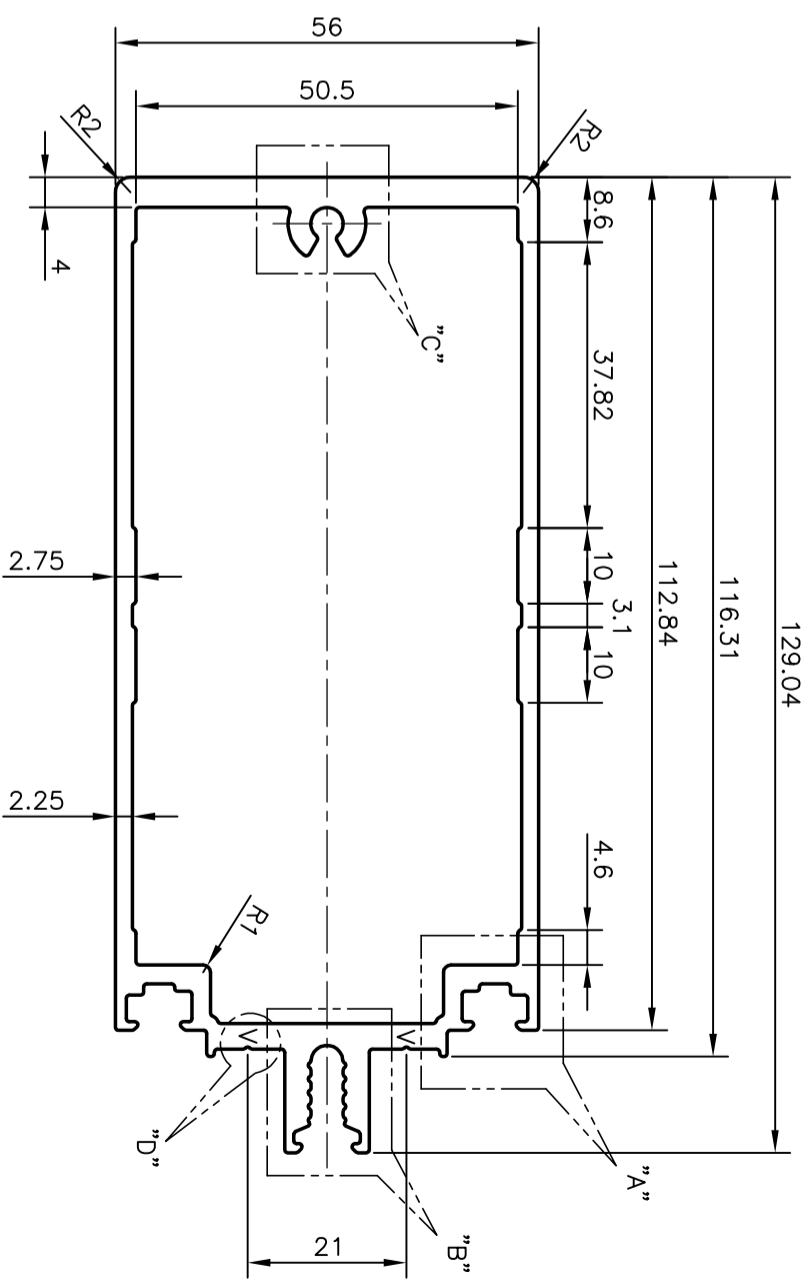

V = VEE-GROOVE 0.3x90° (2 PLACES)

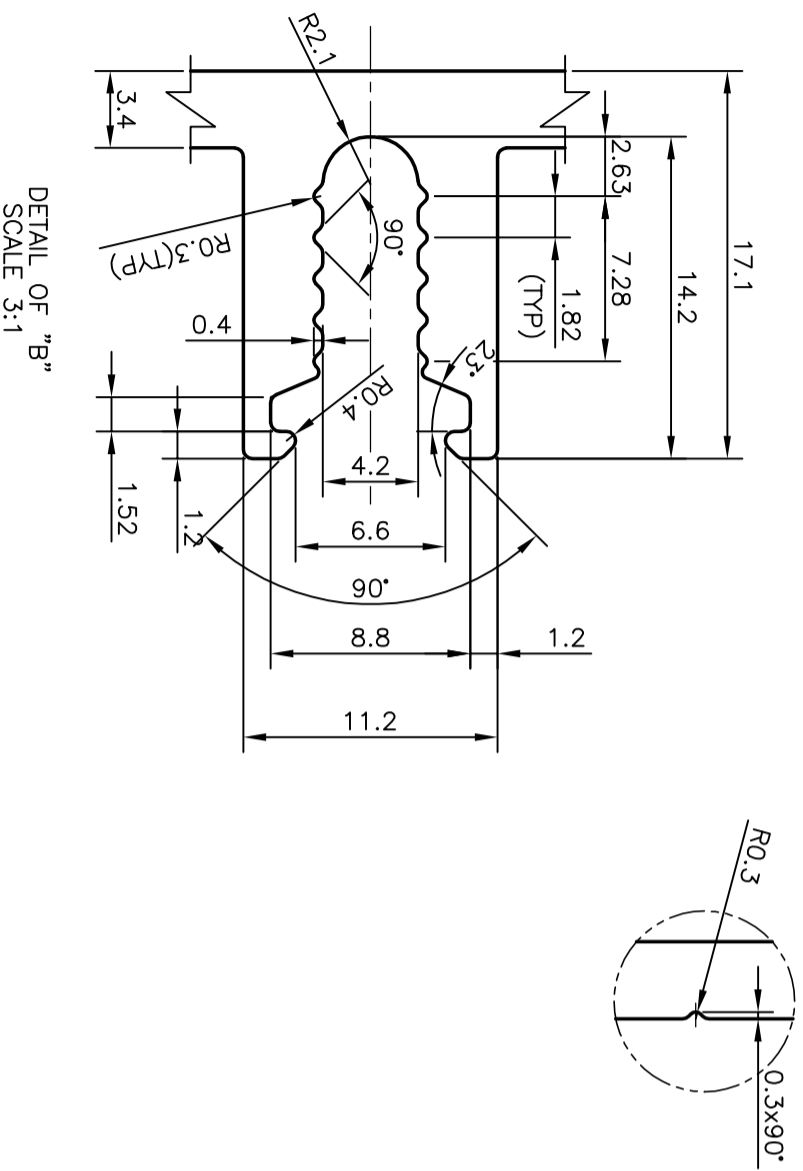

DETAIL OF "B"
SCALE 3:1

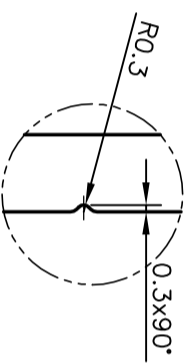

 SYMBOL OF QUALITY AN ISO 9001 COMPANY		JINDAL ALUMINIUM LTD. BANGALORE-560073 (INDIA)		DRAWN	NAME	DATE
				CHECKED	PRASANNAH	12-05-2008
1. ALL DIMENSIONS ARE IN mm. 2. ROUND OFF ALL SHARP CORNERS WITH 0.40 mm. 3. TOLERANCES WILL BE AS PER IS:6477-1983 UNLESS OTHERWISE SPECIFIED		SCALE	1:1			
PARTY'S NAME		GENERAL CATEGORY, CHENNAI MARKET	AREA	mm ² 1058.97		
PARTY'S DRAWING No.		AS PER DRAWING	PERIMETER	mm. 432.344		
ALLOY & TEMPER		HE9 WP	WEIGHT	kg/m 2.859		
DESCRIPTION		TRANSOM SECTION	DRAWING No.	SECTION No.		
			P-8248-1	-		
			29148	29148		