

P-7456

S2072

29156

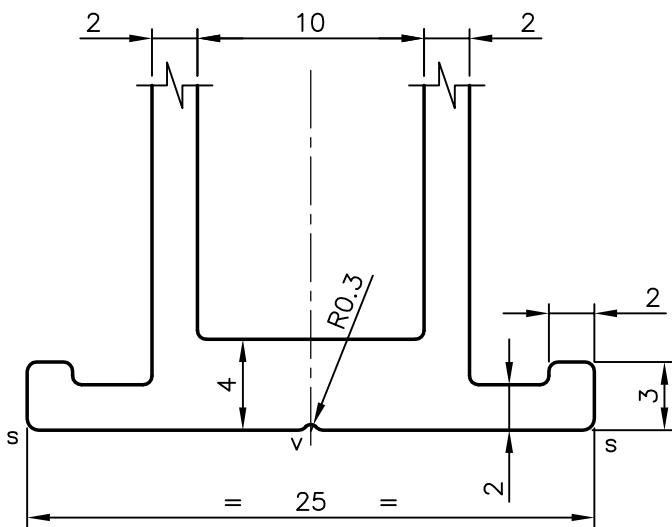
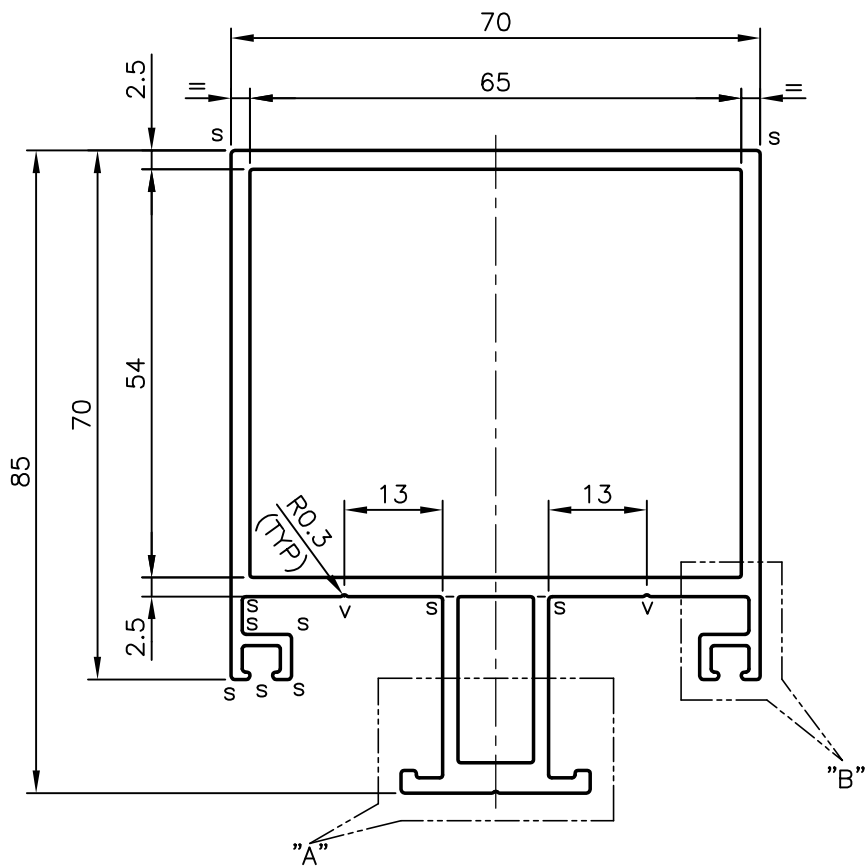

DETAIL OF "A"
SCALE 3:1

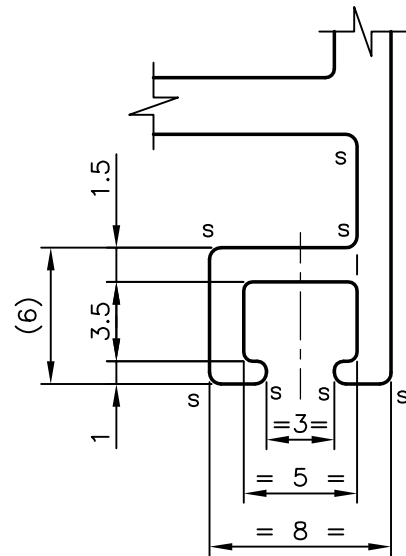

DETAIL OF "B"
SCALE 3:1

NOTE:-

1. s = R0.50 mm (20 PLACES)
2. v = 'V'-GROOVE 0.25x90° (3 PLACES)



SYMBOL OF QUALITY
AN ISO 9001 COMPANY

JINDAL ALUMINIUM LTD.
BANGALORE-560073 (INDIA)

	NAME	DATE
DRAWN	PRASANN.H	17-08-2007
CHECKED		
APPROVED		

1. ALL DIMENSIONS ARE IN mm.
2. ROUND OFF ALL SHARP CORNERS WITH 0.40 mm.
3. TOLERANCES WILL BE AS PER IS:6477-1983 UNLESS OTHERWISE SPECIFIED

SCALE	1:1
AREA mm ²	859.6
PERIMETER mm.	424.715
WEIGHT kg/m	2.321

PARTY'S NAME	MERINT INFRASTRUCTURE LTD., MUMBAI
PARTY'S DRAWING No.	AS PER DRAWING
ALLOY & TEMPER	HE9 WP
DESCRIPTION	CURTAIN WALL-MULLION SECTION

DRAWING No.	SECTION No.
P-7456	-
S2072	S2072
29156	29156