

P-8177

29170

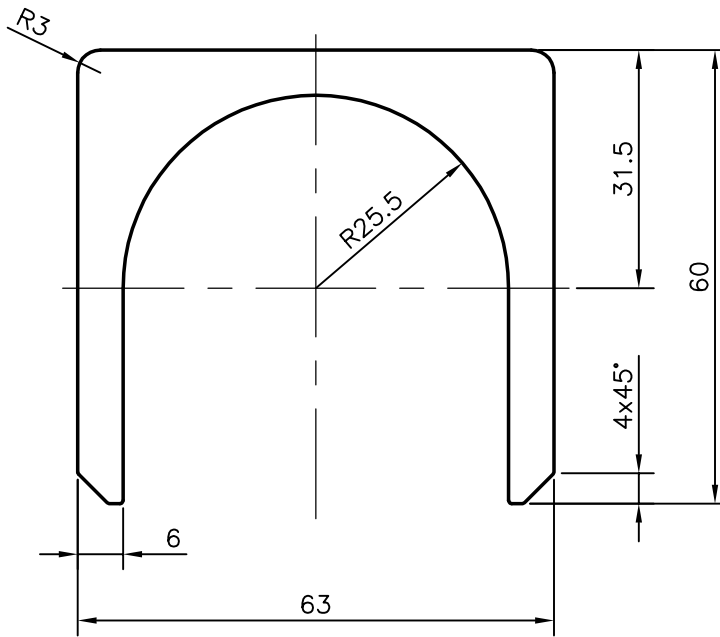

SYMBOL OF QUALITY
AN ISO 9001 COMPANY

JINDAL ALUMINIUM LTD.
BANGALORE-560073 (INDIA)

	NAME	DATE
DRAWN	PRASANNA.H	19-04-2008
CHECKED		
APPROVED		

1. ALL DIMENSIONS ARE IN mm.
2. ROUND OFF ALL SHARP CORNERS WITH 0.40 mm.
3. TOLERANCES WILL BE AS PER BS:EN-755 UNLESS OTHERWISE SPECIFIED

SCALE	1:1
AREA mm ²	1285.144
PERIMETER mm.	324.437
WEIGHT kg/m	3.470

PARTY'S NAME	DOLPHIN MANUFACTURING LTD., L.L.C., U.A.E.
PARTY'S DRAWING No.	AS PER DRAWING & SPECIFICATION
ALLOY & TEMPER	6060 T5
DESCRIPTION	MISC. CHANNEL

DRAWING No.	SECTION No.
P-8177	-
29170	29170