

P-8181-1

29174

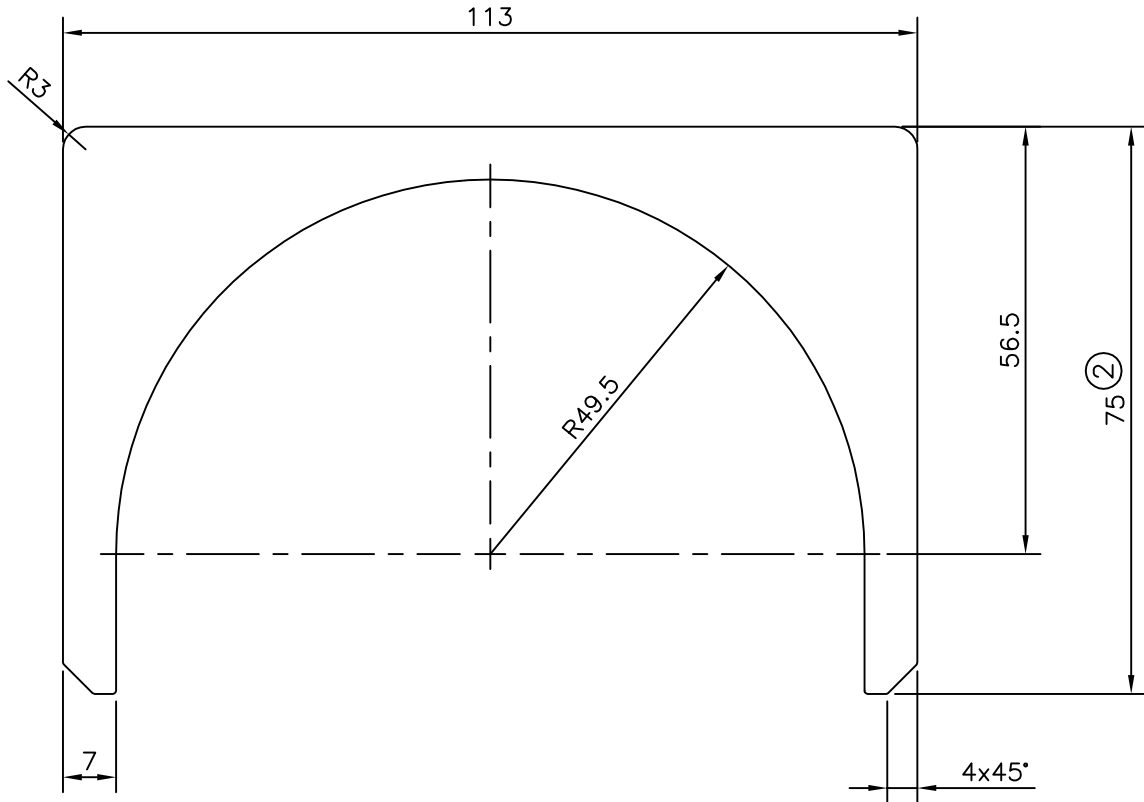

ISSUE:-2

DIMENSIONS CHANGED FROM 70 TO 75 mm  
 WEIGHT ALSO CHANGED FROM 7.303 kg/M TO 7.492 kg/M



SYMBOL OF QUALITY  
 AN ISO 9001 COMPANY

**JINDAL ALUMINIUM LTD.**  
 BANGALORE-560073 (INDIA)

	NAME	DATE
DRAWN	J.P.KAUSHIK	30-12-2013
CHECKED		
APPROVED	S.S.GARG	20-01-2014
SCALE		1:1
AREA mm <sup>2</sup>		2774.711
PERIMETER mm.		461.835
WEIGHT kg/m		7.492
DRAWING No.	SECTION No.	
P-8181-1	-	
29174	29174(ISSUE-2)	

1. ALL DIMENSIONS ARE IN mm.
2. ROUND OFF ALL SHARP CORNERS WITH 0.40 mm.
3. TOLERANCES WILL BE AS PER BS:EN-755-9 UNLESS OTHERWISE SPECIFIED

PARTY'S NAME	DOLPHIN MANUFACTURING LTD., L.L.C., U.A.E.
PARTY'S DRAWING No.	AS PER DRAWING & SPECIFICATION
ALLOY & TEMPER	6060 T5
DESCRIPTION	MISC. CHANNEL