

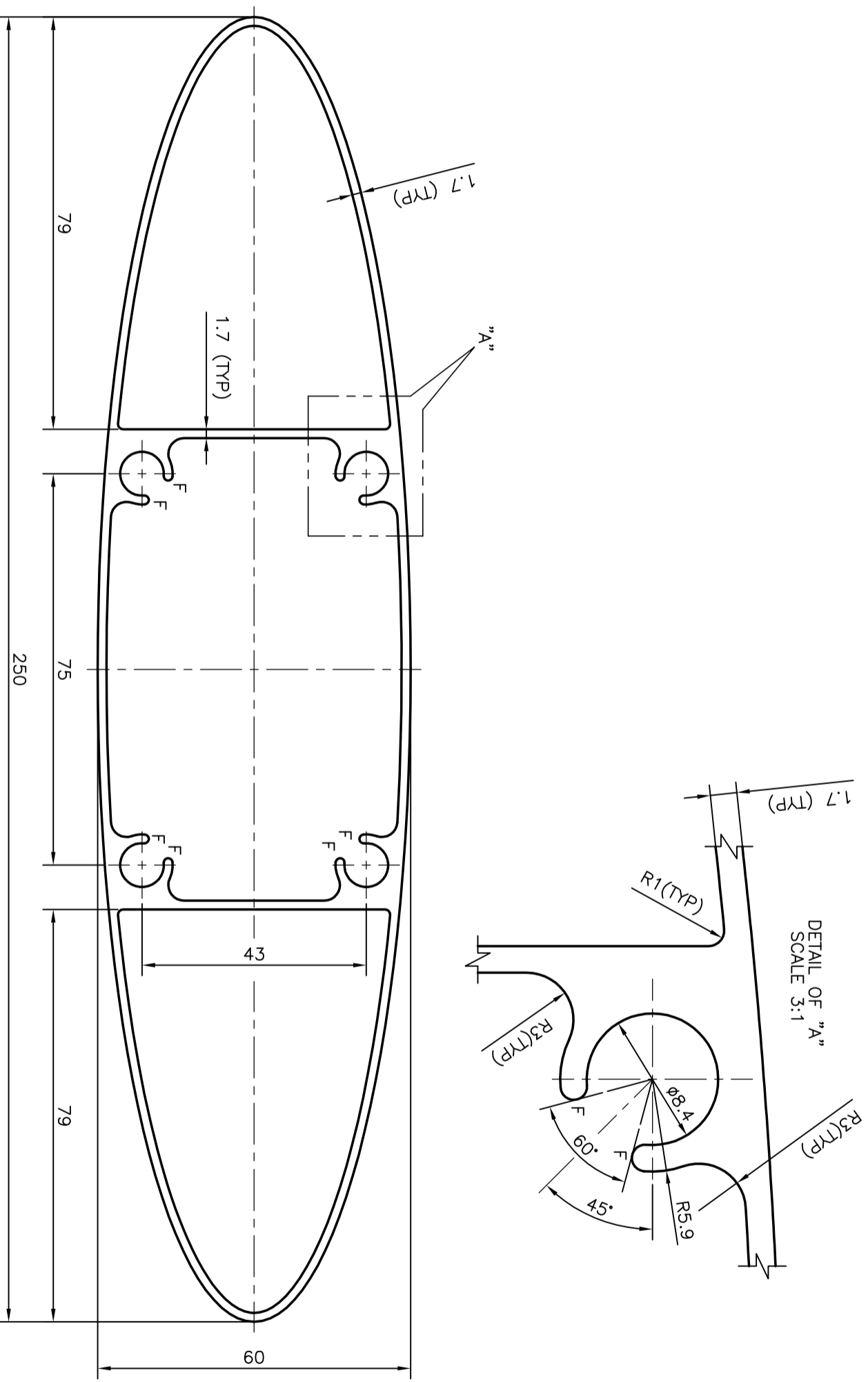

P-8388

29180



F = FULL RADIUS (8 PLACES)

 SYMBOL OF QUALITY AN ISO 9001 COMPANY		JINDAL ALUMINIUM LTD. BANGALORE-560073 (INDIA)		NAME	DATE
1. ALL DIMENSIONS ARE IN mm. 2. ROUND OFF ALL SHARP CORNERS WITH 0.40 mm. 3. TOLERANCES WILL BE AS PER IS:6477-1983 UNLESS OTHERWISE SPECIFIED		DRAWN	PRASANNA.H	17-06-2008	
PARTY'S NAME	ALUPLEX INDIA PVT. LTD., MUMBAI	CHECKED			
PARTY'S DRAWING No.	AS PER DRAWING	APPROVED			
ALLOY & TEMPER	HE9 WP	SCALE		1:1	
DESCRIPTION	LOUVERS SECTION	AREA mm ²		1350.439	
		PERIMETER mm.		533.87	
		WEIGHT kg/m		3.646	
		DRAWING No.		SECTION No.	
		P-8388		-	
		29180		29180	