

P-6341

X571

29184

F = FULL RADIUS (4 PLACES)

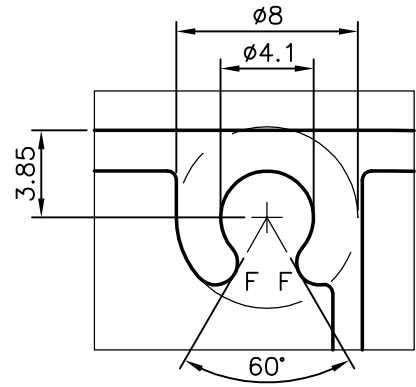

DETAIL-A
SCALE: - 3:1

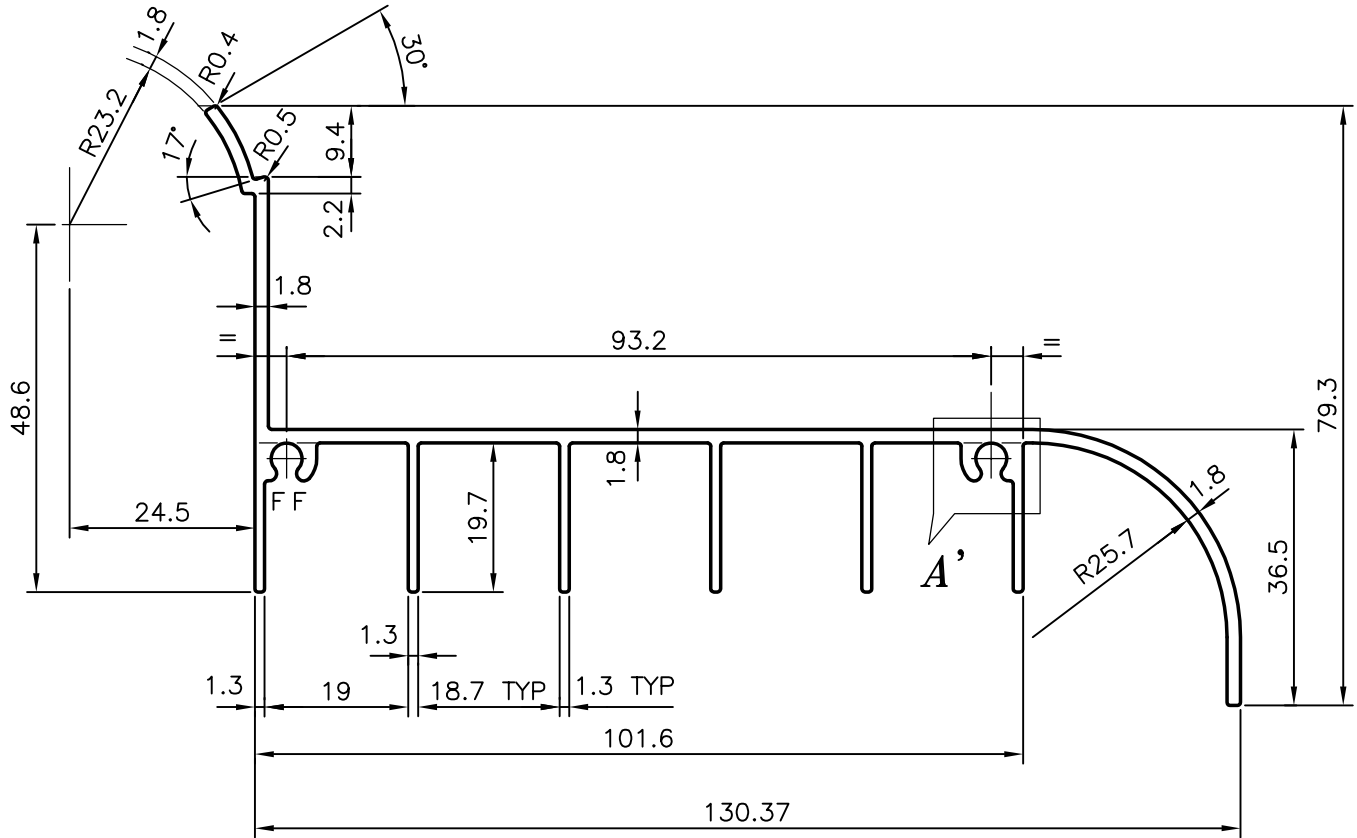

SYMBOL OF QUALITY
AN ISO 9001 COMPANY

JINDAL ALUMINIUM LTD.
BANGALORE-560073 (INDIA)

	NAME	DATE
DRAWN	MALINGAPPA	20-04-2006
CHECKED		
APPROVED		

1. ALL DIMENSIONS ARE IN mm.
2. ROUND OFF ALL SHARP CORNERS WITH 0.40 mm.
3. TOLERANCES WILL BE AS PER IS:3965-1981 UNLESS OTHERWISE SPECIFIED

SCALE	1:1
AREA mm ²	546.564
PERIMETER mm.	649.736
WEIGHT kg/m	1.476

PARTY'S NAME: MACART EQUIPMENT PVT. LTD., PUNE

PARTY'S DRAWING No.: AS PER DRAWING

ALLOY & TEMPER: HE9 WP

DESCRIPTION: MISC. SECTION

DRAWING No.	SECTION No.
P-6341	-
X571	X571
29184	29184