

P-8311

29189

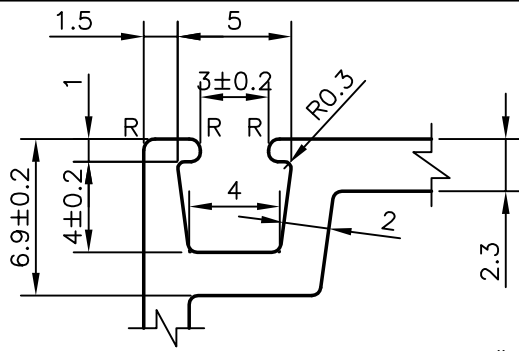

DETAIL OF "A"
SCALE 3:1

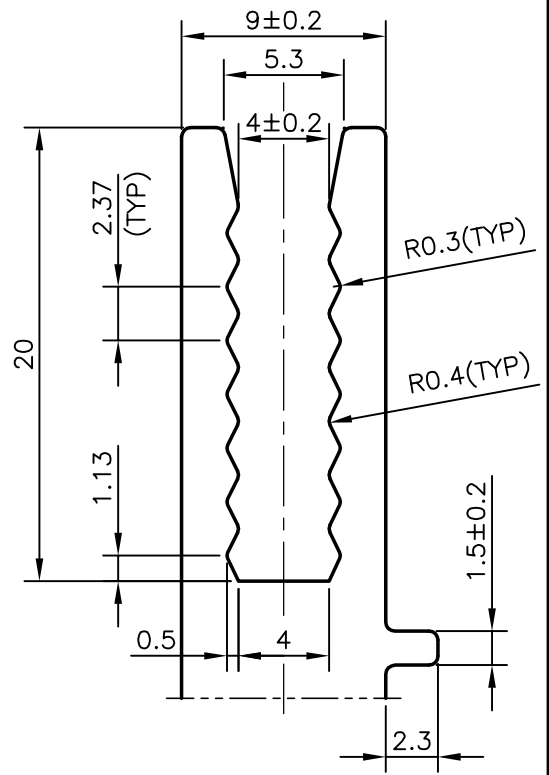

DETAIL OF "B"
SCALE 3:1

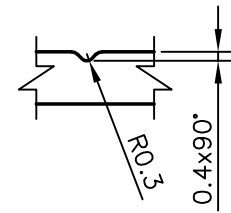
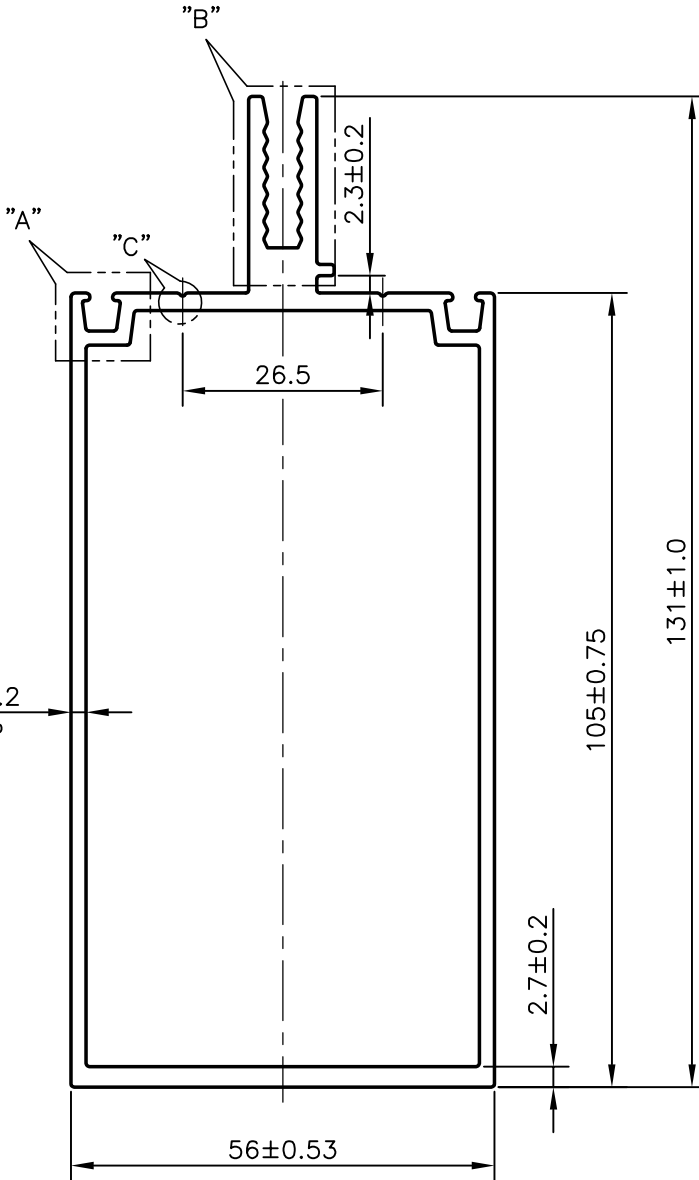

DETAIL OF "C"
SCALE 3:1

R = R0.50 mm (6 PLACES)



SYMBOL OF QUALITY
AN ISO 9001 COMPANY

JINDAL ALUMINIUM LTD.
BANGALORE-560073 (INDIA)

	NAME	DATE
DRAWN	PRASANNA.H	26-05-2008
CHECKED		
APPROVED		

1. ALL DIMENSIONS ARE IN mm.
2. ROUND OFF ALL SHARP CORNERS WITH 0.40 mm.
3. TOLERANCES WILL BE AS PER IS:6477-1983 UNLESS OTHERWISE SPECIFIED

SCALE	1:1
AREA mm ²	839.821
PERIMETER mm.	442.257
WEIGHT kg/m	2.268

PARTY'S NAME	GLOBAL HEALTH CENTRE PVT. LTD., GURGAON
PARTY'S DRAWING No.	AS PER DRAWING
ALLOY & TEMPER	HE9 WP
DESCRIPTION	CURTAIN WALL SECTION

DRAWING No.	SECTION No.
P-8311	-
29189	29189