

P-6471
X581
29195

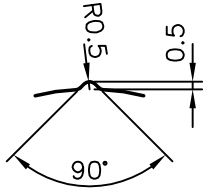

V = 0.5x45°xR0.50 (4 NOS)

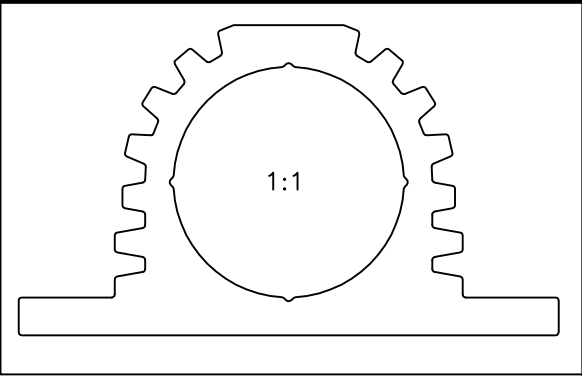
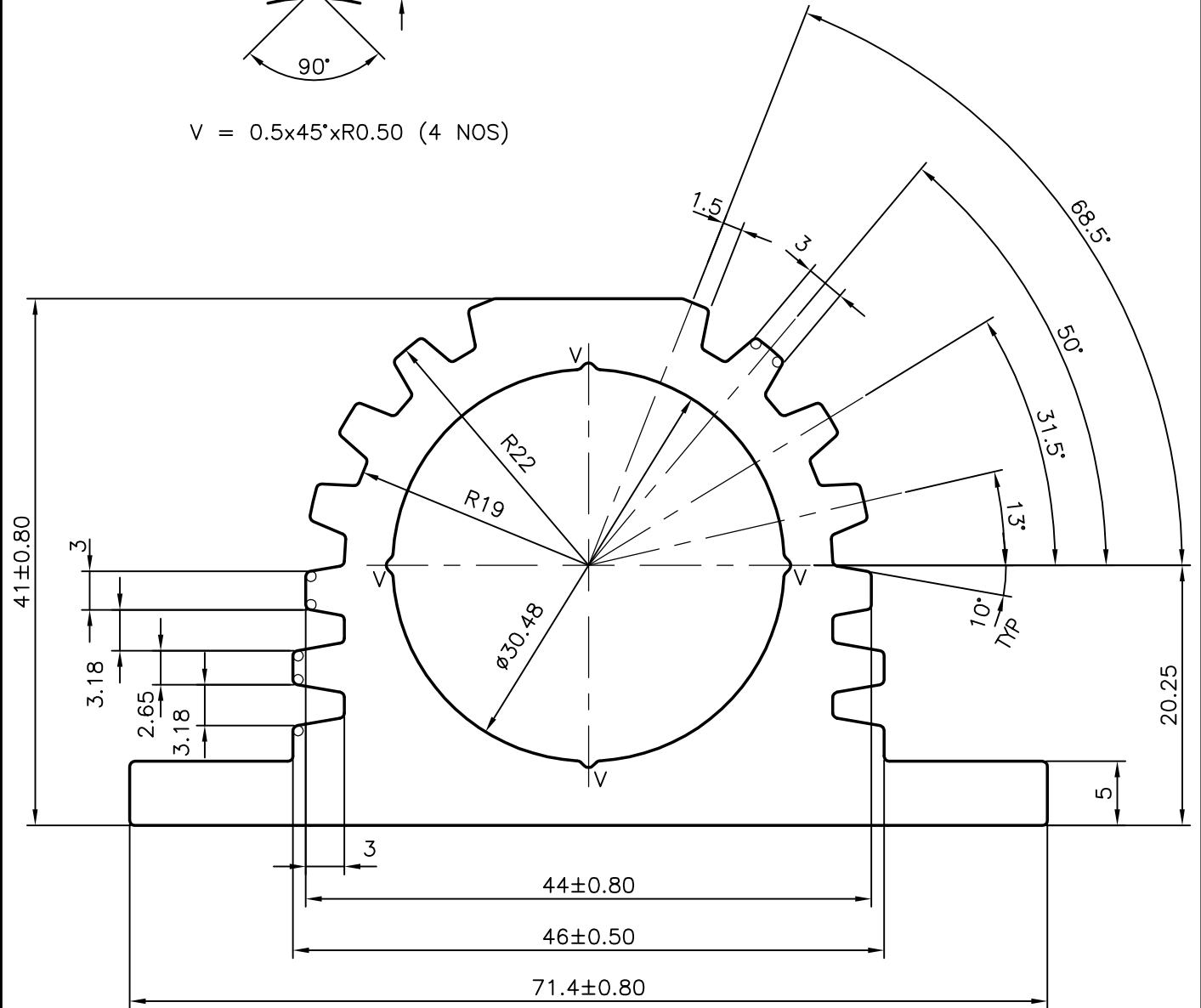

JINDAL ALUMINIUM LTD.
BANGALORE-560073 (INDIA)

	NAME	DATE
DRAWN	J.P.KAUSHIK	05-06-2006
CHECKED		
APPROVED		

1. ALL DIMENSIONS ARE IN mm.
2. ROUND OFF ALL SHARP CORNERS WITH 0.40 mm.
3. TOLERANCES WILL BE AS PER IS:6477-1983 UNLESS OTHERWISE SPECIFIED

SCALE	2:1
AREA mm ²	948.397
PERIMETER mm.	259.202
WEIGHT kg/m	2.561

PARTY'S NAME	K.S. INSTRUMENTS PVT. LTD., BANGALORE
PARTY'S DRAWING No.	KSI/TYC/EXT/08
ALLOY & TEMPER	HE9 WP
DESCRIPTION	MISC. TUBE

DRAWING No.	SECTION No.
P-6471	-
X581	X581
29195	29195